

# RF COMMUNICATIONS

**A Non-Technical Approach**

**Presented by  
Decibel Products**

*About:*

- Base Station Antennas

- Combiners

- Selective Cavities

- Duplexers

- RF Transmission Lines

- Lightning

# About RF Communications

A Non-Technical Approach

---

Presented by Decibel Products

First published as a series of individual booklets by

Decibel Products

8635 Stemmons Freeway, Dallas, Texas 75247-3701

P. O. Box 569610, Dallas, Texas 75356-9610

Tel: (214) 631-0310

Fax: (214) 631-4706

Editing and Design: Steven Patterson

Graphic Illustration: Carla Brown, Steve Claxton

Marketing Communications Manager: Devra D. Fuller

Printing: Ussery Printing Company, Irving, Texas

All rights reserved.

No part of this book may be reproduced in any way without the expressed written permission of the publisher.

Printed in the U. S. A.

Copyright ©1964, 1965, 1970, 1973, 1975, 1996

by Decibel Products, a division of the Allen Telecom Group.

Any trademarked names appearing in this book are the property of their respective holders. They are used only for editorial purposes and the publisher wishes no infringement upon them.

**Limits of Liability and Disclaimer of Warranty**

The publisher has used its best efforts in preparing this book and the information it contains. The publisher makes no warranties of any kind, expressed or implied, with regard to the instructions and suggestions contained in this book. The publisher shall not be liable in the event of incidental or consequential damages in connection with, or arising out of, the furnishing, performance, or use of any instructions or suggestions contained in this book.

# Table of Contents

Introduction .....	v
<b>CHAPTER 1</b>	
<b>Base Station Antennas .....</b>	<b>1-1</b>
What is an antenna? .....	1-1
Matching and VSWR .....	1-2
Wavelength, Frequency, and Velocity .....	1-3
Antennas Work the Same	
When Transmitting or Receiving .....	1-4
The Half-Wave Dipole .....	1-4
Antenna Polarity .....	1-5
Vertical and Horizontal Antenna Radiation Patterns .....	1-6
No True Omnidirectional Antennas .....	1-6
Antenna Gain .....	1-7
What About That Word Decibel? .....	1-7
How Do We Get Antenna Gain? .....	1-7
Squashing the Doughnut .....	1-9
Omnidirectional Pattern Gain Antenna .....	1-9
In Phase and Out of Phase .....	1-10
Aperture .....	1-13
Spacing of Dipole Elements	
in the Vertical Collinear Array .....	1-13
Feeding the Collinear Array .....	1-14
Maximum Gain from a Collinear Array .....	1-14
Directional Gain Antennas .....	1-15
The Dipole and Reflector .....	1-16
The Corner Reflector and Parabolic Reflector .....	1-16
The Yagi Antenna .....	1-16
How Many Elements? .....	1-17

Phased Radiators for Directivity .....	1-18
A Bidirectional Array or Figure-Eight Pattern .....	1-19
Additional Gain by Stacking Directional Antennas .....	1-19
Side Mounted Antennas .....	1-20
Then How Do We Get an Omni Pattern? .....	1-20
Noise .....	1-20
What Do We Mean by Noise? .....	1-21
What Happens to Noise with Gain? .....	1-21
What About the 450 MHz Band? .....	1-22
What About the Countryside? .....	1-22
Bandwidth .....	1-22

**CHAPTER 2**

**Combiners ..... 2-1**

Combiner Requirements .....	2-2
Cavity Type Combiners .....	2-2
All Bandpass Combiners .....	2-3
Notch Filter Combiner .....	2-4
Bandpass-Notch Combiners .....	2-6
Transmitter Intermodulation .....	2-8
Typical System Analysis .....	2-8
The Ferrite Isolator .....	2-10
Low-Loss Type Transmitter Combiner .....	2-11
Low-Loss Transmitter Combiner	
For Close Frequency Spacing .....	2-12
The Hybrid Coupler .....	2-14
The Hybrid Combiner .....	2-14
The Receiver Multicoupler or Combiners .....	2-16
A Complete System Configuration .....	2-16
Combiner Selection .....	2-17

**CHAPTER 3**

**Selective Cavities ..... 3-1**

What is a Selective Cavity and What Does it Do? .....	3-1
How it Works .....	3-3
Selectivity .....	3-3
Insertion Loss .....	3-6
How to Obtain Selectivity .....	3-6
Internal Losses .....	3-6
Determine the "Q" of the Cavity .....	3-7
Obtaining Greater Selectivity .....	3-7
Dissipating Power in the Cavities .....	3-8
More About Coupling Loops .....	3-10
Stability .....	3-10

Cavity Installation .....	3-11
Tuning .....	3-12

**CHAPTER 4**  
**Duplexers ..... 4-1**

The Simplex System .....	4-2
The Duplex System .....	4-2
Why No Duplexer? .....	4-4
The Need for Isolation .....	4-5
Receiver Selectivity .....	4-5
Receiver Desensitization .....	4-6
Transmitter Noise .....	4-7
Isolation Between Transmitter and Receiver .....	4-8
Obtaining Isolation .....	4-10
Horizontal Antenna Separation .....	4-10
Vertical Antenna Separation .....	4-10
Using a Duplexer .....	4-11
The Advantages of a Duplexer .....	4-12
Things a Duplexer Must Do .....	4-13
Losses Through the Duplexer .....	4-14
The Bandpass Cavity .....	4-14
The Bandpass Duplexer .....	4-15
The Cable Harness .....	4-17
Band-Reject Filters and Band-Reject Duplexers .....	4-18
The Band-Reject Duplexer .....	4-19
The Cable Harness .....	4-21
Other Facts About Duplexers .....	4-21
Use of Duplexers As Combiners .....	4-22
Power .....	4-23
Temperature .....	4-23
Frequency Separation .....	4-23

**CHAPTER 5**  
**RF Transmission Lines ..... 5-1**

Types of Cables .....	5-2
Mechanical Elements of a Coaxial Cable .....	5-3
Electrical Properties of Coaxial Cable .....	5-4
Characteristic Impedance .....	5-4
Velocity of Propagation .....	5-5
Power Handling Capability .....	5-5
RF Leakage .....	5-6
Environmental Considerations .....	5-6
Life Expectancy of Coaxial Cables .....	5-6
Moisture Resistant RG Type Cable .....	5-7

Corrosion .....	5-8
Galvanic Series .....	5-8
Connectors .....	5-9
Installation of Coaxial Cable .....	5-11
Selecting the Proper Coaxial Cable .....	5-12
The Installation Environment .....	5-13
Field Testing Coaxial Cable .....	5-13
Standing Waves or VSWR .....	5-14
Problems and Solutions .....	5-14
High VSWR .....	5-15
Preventive Maintenance .....	5-16

**CHAPTER 6**

<b>Lightning .....</b>	<b>6-1</b>
Exposure Factors .....	6-1
Evaluation of Lightning Exposure .....	6-2
Lightning Current .....	6-2
Types and Incidence of Thunderstorms .....	6-3
Cycle of a Lightning Strike .....	6-4
Introduction to Grounding .....	6-6
Grounding Philosophy .....	6-7
Equalizing Potentials .....	6-8
Antennas and Supporting Structures .....	6-8
Two-Way Radio Antennas .....	6-10
Microwave Antennas .....	6-10
Two-Way Radio Antenna Support Structures .....	6-11
Microwave Antenna Support Structures .....	6-11
Antenna Support Structures on Buildings .....	6-14
Coaxial Lines and Waveguides .....	6-14
Lightning Safety Tips .....	6-15

# Introduction

This book has been written for the many people engaged in RF communications who are not radio engineers. A non-technical look at the complex aspects of RF communications is presented to bring about a better understanding of the world of two-way radio systems.

While we can't possibly expect anyone to become an expert on RF communications simply by reading this material, if some of the mystery is unveiled and the picture seems a little clearer, we will feel amply rewarded for our efforts.





# Base Station Antennas

It's obvious that the antenna system is an important part of an RF communication system — without it the system wouldn't work. Equally obvious is the fact that the antenna system is common to both the transmitter and the receiver; any change made in the antenna system affects both transmission and reception.

This brings us quickly to consider the economics of a radio system. We can help the talk-out range — base station to mobile — by doubling the transmitter power, but this doesn't help the talk-back range — mobile to base — in the least.

On the other hand, if we can change the antenna to effectively double the transmitter power (and we'll see how this is done a bit later in our discussion), then the power of the mobile transmitters will also be effectively doubled.

By changing the antenna system we help both base-to-mobile and mobile-to-base ranges. And, generally, it is less expensive to change the antenna system than it is to change the transmitter power of the base and mobile units.

## **What is an antenna?**

The antenna is the portion of the radio system found at the top of the tower. It could be a simple one-element antenna, or it could be a complex multi-element array. The antenna takes radio energy from the transmission line and radiates it into space; it also receives radio energy from space and



feeds the received energy down the transmission line to the receiver. To oversimplify, an antenna is designed to radiate radio energy into space and collect radio energy from space.

We already know that an antenna changes radio energy from the transmission line into radiated energy and vice versa. What is remarkable, though, is how efficiently this occurs.

A common household light bulb is only about 20 percent efficient in changing electrical energy into light (another form of radiation), whereas a two-way antenna is nearly 100 percent efficient.

Of course, we don't quite get all of the energy out that we put in. Factors affecting this include a coaxial line that doesn't perfectly "match" the input to the antenna and power lost due to such things as "skin effect," insulator dielectric, eddy currents, etc.

But, since we can typically claim that an antenna radiates better than 95 percent of the watts it receives from the coaxial line — provided it "matches" the line — an antenna is a pretty efficient device when compared to most other energy-emitting things we know.



## Matching and VSWR

If we consider an automobile, we know that the various gears must match if we are to transmit maximum power to the wheels. Similarly, to get maximum power from our radio system, we must match the transmitter to the coaxial line and antenna.

We match the transmitter to the coaxial line by tuning or adjusting its output circuit. And, since standard coaxial lines are fixed at 50 ohms for the two-way industry, we must design and adjust the antennas to be reasonably close to 50 ohms.

If we were to connect our transmitter to a 50 ohm coaxial line, then put a 50 ohm dummy load at the end of the line, we could use a watt meter to read: (1) the power going into the line from the transmitter and, (2) the power reaching the dummy load. Any difference in the two power values represents the power lost in the transmission line.

If the dummy load matches the line perfectly, all the power reaching the dummy load will be dissipated and no power

will be returned to the transmitter. All of the power will be consumed, either in the line or in the dummy load.

Now, let's suppose we change the dummy load to 25 ohms. This would be like an automobile gear with half its teeth missing; it can't accept all the power presented to it. Half of the power that would have been transferred from gear "A" to gear "B" remains in gear "A"; in other words, it's sent back to its point of origin.

In a radio system, when the elements aren't properly matched, the element that is mismatched rejects part of the signal and sends it back down the line. This rejected signal is then reflected back and forth between the load — or the antenna — and the transmitter. This sets up a fixed, measurable wave pattern along the line; we call this the Standing Wave Ratio (SWR) or the Voltage Standing Wave Ratio (VSWR).

The SWR, or VSWR as it is typically referred to, is expressed as a ratio. This ratio expresses the degree of match between the line and the antenna, or load. When the VSWR is one-to-one (expressed as 1.0:1) a perfect match exists. If the VSWR is 1.5:1, the percentage of reflected power is only 4%, or, stated another way, 96% of the power that gets to the end of the line goes into the antenna.

### **Wavelength, Frequency, and Velocity**

We know that a radio wave travels at the same speed as a beam of light — around 186,000 miles per second, or nearly a billion feet per second. This is its speed or velocity.

We also know that a radio wave oscillates or alternates from plus to minus, back to plus, back to minus, etc. The variation from plus to minus and back to plus is called one cycle or one hertz — since, like a wheel, it repeats itself (see Figure 1-1).

The number of cycles the signal goes through in one second is called the frequency. If we know the frequency (which we can measure), we can then find out how far the wave travels in one cycle by dividing the speed by the frequency. We call this distance a wavelength and we generally measure it in feet or inches. Half of this distance, or the distance between a plus and a minus change in the wave, is called a half wavelength. A list of wavelengths over the



ranges of frequencies used in two-way communications is shown in Figure 1-2.

An idea of the size of a wavelength, or a half wavelength, is useful when we consider how antennas radiate “in phase” or “out of phase.”

### **Antennas Work the Same When Transmitting or Receiving**

Fortunately, for two-way radio users, antennas receive equally as well as they transmit. This is true even though it doesn't always seem that way in actual performance. Due to such things as noise and interference, the antenna's true performance in the receive mode can be masked.

Let's start with a basic type of antenna and use it as a stepping stone to understanding more complex gain arrays.

### **The Half-Wave Dipole**

The most basic antenna we use in two-way base stations is the half-wave dipole radiator. The half-wave dipole is simply a straight conductor made of wire, rod, or tubing that, electrically, is one-half wavelength long. Generally, the feed line attaches at the middle. It radiates at maximum intensity in the middle of the dipole, at right angles to its length; the minimum intensity is at its ends (see Figure 1-3).

In two-way mobile radio services, the half-wave dipole — commonly referred to simply as a dipole — is the accepted reference standard when we state performance or gains of other types of antennas. Gain is to antennas what horsepower is to automobiles; it is a measure of performance power.

Since dipole antennas radiate best when at a resonant length relative to the desired frequency, they are generally cut or adjusted in length to a desired frequency. Furthermore, the electrical half wavelength is generally a few percent shorter than the physical half wavelength. This is done to allow for what is called “end effect” of the conductor.

A rule of thumb for the length of the half-wave dipole radiator is: Length (in feet) equals 492 divided by the frequency in megahertz (MHz). This says that a half-wave dipole at our lowest frequency of 25 MHz is approximately 20 feet long, while at our highest frequency of 470 MHz it is only about



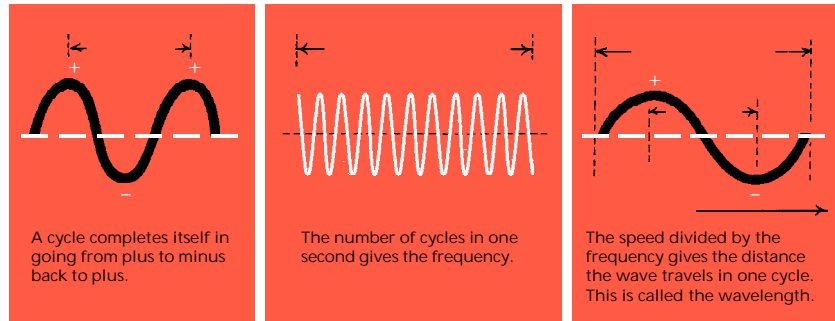

Figure 1-1: Relationship of Time, Frequency, and Wavelength

Frequency (MHz)	1/2 Wavelength (Feet)	Frequency (MHz)	1/2 Wavelength (Feet)
25	19.7	150	3.3
30	16.4	160	3.1
35	14.1	170	2.9
40	12.3		
45	10.9	450	1.1
50	9.8	460	1.07
74	6.7	470	1.05

Figure 1-2: 1/2 Wavelengths of Two-Way Frequencies

one foot long. It's good to keep these lengths in mind when we start talking about antenna arrays or stacking dipoles on towers.

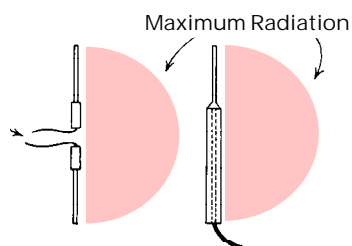

Figure 1-3: Basic Halfwave Dipoles

### Antenna Polarity

Antenna polarity simply refers to how the antenna is oriented or positioned. If the radiating elements are oriented vertically, then it will have vertical polarization; if the elements are oriented horizontally, it will have horizontal polarization.

For mobile radio services, vertical polarization is the accepted standard



since it is easier to install a vertical whip on a vehicle than it is to install a horizontal one. If our mobile antenna is vertically polarized, then, of course, our base station must be vertically polarized if we are to obtain maximum efficiency and range from the combination.

### Vertical and Horizontal Antenna Radiation Patterns

All antennas have a given three-dimensional radiation pattern. If the radiation patterns were equal in all directions, it would be that of a round ball or a sphere.

If we cut the sphere vertically we would see the vertical pattern, which would be a circle. On the other hand, if we cut the sphere horizontally we would see the horizontal pattern, and it too would be a circle. We could then say that the vertical pattern was omnidirectional and the horizontal pattern was omnidirectional, and that the two were equal.

### No True Omnidirectional Antennas

In the previous paragraph, we stated that the antenna patterns would be omnidirectional. In actual practice, however, there is no truly omnidirectional antenna — it exists only in theory. Our half-wave dipole antenna, mounted vertically, as used in two-way communications, has a three-dimensional pattern as shown in Figure 1-4a. It appears as a large, fat doughnut. Its horizontal pattern (Figure 1-4b) is circular, but its vertical pattern (Figure 1-4c) looks like a fat figure-eight lying on its side.

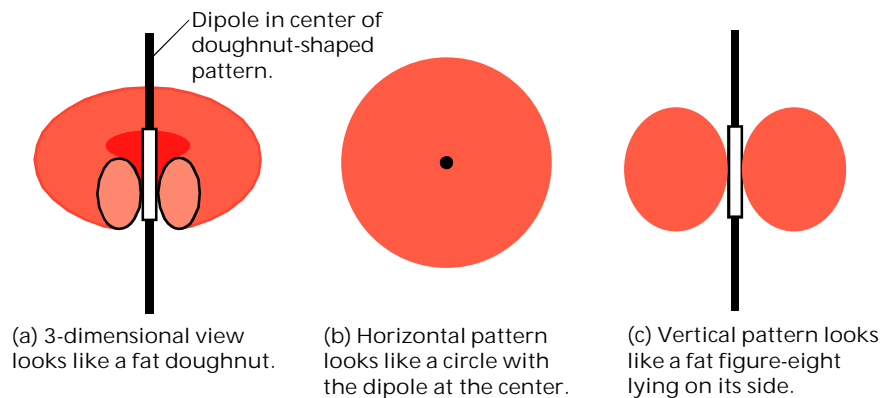

Figure 1-4: Radiation Patterns of a Dipole

In two-way mobile communications we really aren't concerned so much about the antenna's vertical pattern. In the field, we are always working at horizon elevations, even with a tall tower on the top of a hill.

For example, if our antenna is mounted on a tower that is 200 feet tall and the tower is on a hill that is 200 feet high, we would consider the antenna to be 400 feet high.

At a distance of, let's say, 20 miles, the angle between the base antenna and the mobile unit would be less than one degree — or, for practical purposes, the horizon level itself. It's in the greater ranges where we need maximum gain and where we're concerned with the antenna pattern and gain.

### **Antenna Gain**

Antenna gain and pattern shape are interrelated; if you change one, you generally change the other.

Just as we need a starting or reference point when we survey land, we must have a reference point to start from when we talk about gain. In addition, just as inches, feet, and miles, (or centimeters, meters, and kilometers), etc., are used as a unit of measure in surveying land, we need a unit of measure when we talk about gain.

The reference we use in two-way base station antennas is the half-wave dipole and the unit of measure is the decibel. As the point of reference, we use the half-wave dipole and say it has a gain of one (or unity), or stated in decibels, it has a value of zero decibels.

### **What About That Word Decibel?**

The decibel (usually abbreviated as dB), is used to compare one power level to another. For example, if we have an antenna that has twice the power gain of the half-wave dipole, we can find the power ratio of 2.00 in the table in Figure 1-5 and see that the our antenna will have a 3 dB gain over a half-wave dipole.

### **How Do We Get Antenna Gain?**

There are only two approaches to antenna gain:

1. We could increase, or multiply, the power or current density in the antenna so the antenna radiates a given pat-





tern shape with greater intensity. Unfortunately, however, we can't increase the power, so this can't be done.

2. The other option is to change the shape of the pattern so it radiates more of the antenna's signal in a particular direction. This is something we can do.

Since we don't need radiation in all directions, we can increase the signal's intensity by changing the shape of the antenna pattern. We do this by designing the antenna so that it radiates the same amount of total power, but we change the shape of the pattern so that it directs the radiation where we want it.

To get a better idea of how this works, let's compare it to a lawn sprinkler. The sprinkler head, which would represent the antenna, is attached to a water hose; the water hose would represent the transmission line. If we adjust the sprinkler head so that it covers a full circle and turn the water on full force — that is, we set it at full power — we distribute the water in a circular pattern around the sprinkler head.

Now, if we readjust the head so that it only covers one corner of the lawn and turn the water on full force again, we output the same amount of water as before, but this time,



Power Ratio	dB	Power Ratio	dB
0.10	-10	1.00	0
0.13	- 9	1.26	1
0.16	- 8	1.58	2
0.20	- 7	2.00	3
0.25	- 6	2.50	4
0.32	- 5	3.16	5
0.40	- 4	4.00	6
0.50	- 3	5.00	7
0.63	- 2	6.30	8
0.79	- 1	8.00	9
1.00	0	10.00	10

Figure 1-5: Power Ratios Converted to Decibels

because we have limited the pattern to one direction, the water — or our antenna signal — goes further and outputs more into a given direction.

### Squashing the Doughnut

Let's look at the doughnut pattern of the dipole again (see Figure 1-6a). If we squash it down on top, it will flatten out into a round, flatter shape (see Figure 1-6b; and the more we squash it, the flatter it gets and the larger in diameter it becomes. In other words, the horizontal area is increased at the expense of the high vertical area. And, this is exactly what we want.

Since we don't have any mobile units running around in space, we don't want the radiation to be wasted up there. By flattening, or squashing, the signal we now have an omnidirectional or horizontal pattern which has more gain than the original dipole pattern. This is the desired antenna pattern for a base station that needs maximum range in all directions.

### Omnidirectional Pattern Gain Antenna

To achieve greater gain with an omnidirectional pattern, we can "stack" multiple vertical dipoles above each other as

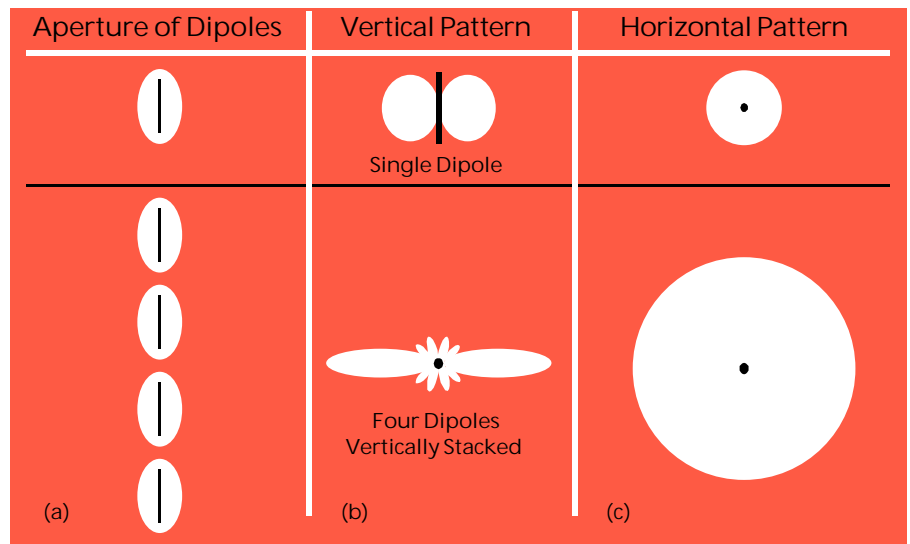

Figure 1-6: This figure illustrates how stacking four dipoles vertically in line changes the pattern shape (squashes the doughnut) and increases the gain over a single dipole. The area of the horizontal pattern measures the gain. The small lobes in the lower center section are secondary minor lobes.

shown in Figure 1-6b. This increases the vertical size or aperture of the signal.

We then feed the dipoles with power in such a way that the radiation from the individual dipoles will add together at a distant point. Also, we must connect the dipoles together so they "match" the cable if we want to get the most radiated power out of the antenna. The most radiated power is obtained when the dipoles are: (1) lined up vertically (collinear) with optimum spacing between them and, (2) fed with equal power that arrives at the dipoles at the same instant (in phase).

This type of antenna is called a collinear (vertical) phased array. And, since it is the most common and most popular type of base station gain antenna, it's important that we examine it a little closer.

### **In Phase and Out of Phase**

Referring to Figure 1-7, let's look at the things that cause the radiation from two or more dipoles to be either "in phase" or "out of phase." When we look at these examples, we'll imagine we are standing at a particular point that is located some distance from the dipoles.

In the first example (see Figure 1-7a), we have two dipoles: "A" and "B". They are positioned vertically, one above the other and have a separated distance of about one wavelength between their centers. Several miles away, an observer with an antenna and receiver is located at point "X". Point "X" is the same distance from each dipole.

Dipoles "A" and "B" are each connected to a transmitter by two coaxial cables of equal length. This means that the power from the transmitter arrives at "A" and "B" at the same instant. Also, since each dipole is connected to its transmission line in the same manner, the dipoles start radiating in the same direction at the same time.

Now, since the observer's antenna at point "X" is the same distance from each dipole, it will receive the two signals at exactly the same time. And, together, the two signals will add up to give a stronger signal. We say that the two dipoles are "in phase."

In Figure 1-7b, we have the same setup as Figure 1-7a except we move dipole "B" closer to observer "X" by one-half

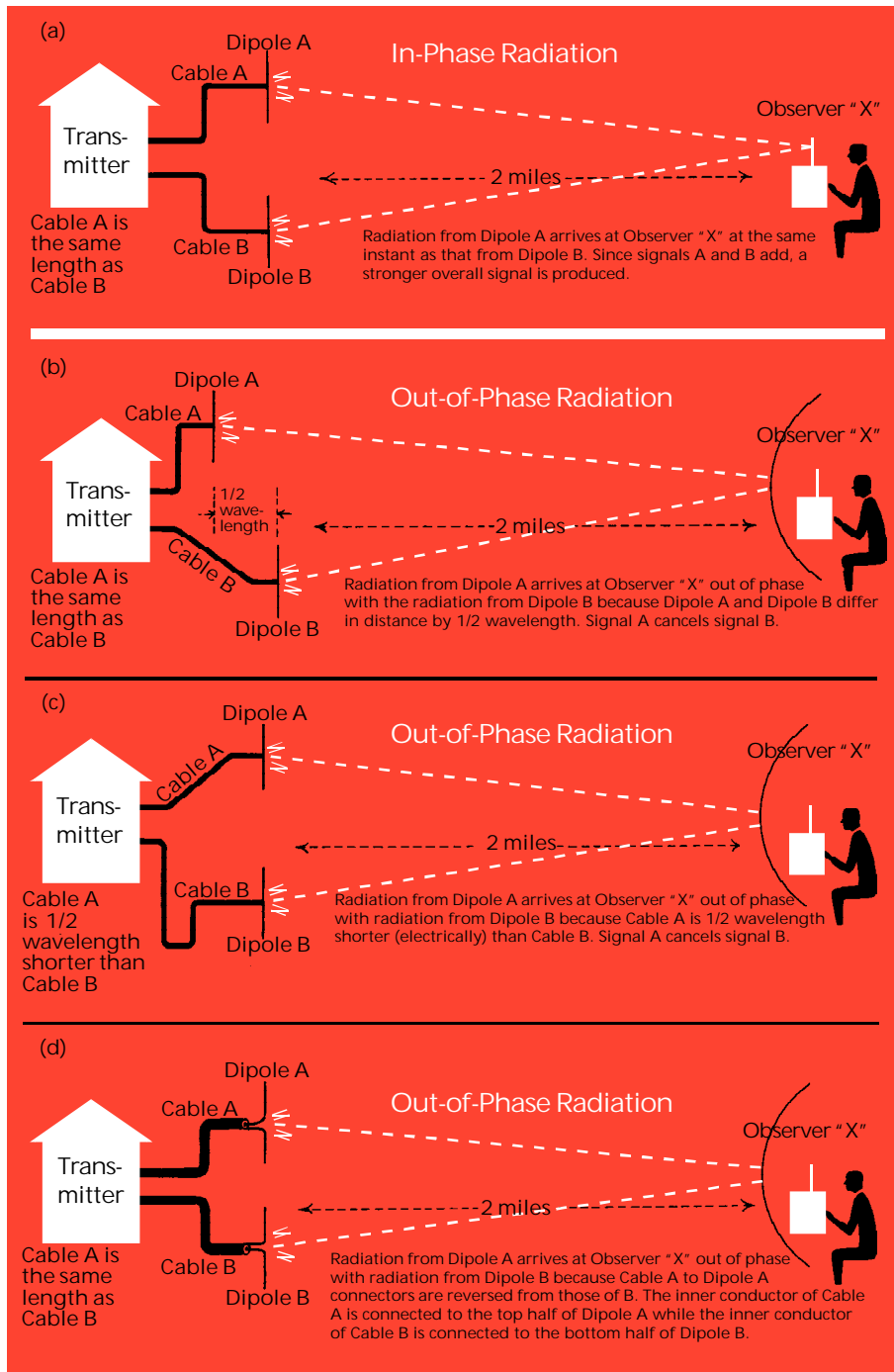

Figure 1-7: In-Phase and Out-of-Phase Radiation

wavelength. Now, the signal from dipole "B" arrives at point "X" one-half cycle sooner than the signal from dipole "A". When "A" is going minus, "B" is going plus and the signal is canceled. We say the two are "out of phase."

Now, suppose observer "X" had a hot air balloon and could go up in the air and find some spot where the distance was the same between himself and the two dipoles; here the radiation would again add together, they would be in phase. In this situation, we would say the beam was tilted up.

We could also say this would be a poor base station antenna. The radiation was not destroyed or lost by phase cancellation, instead it was just repositioned or reshaped in pattern.

Figure 1-7c shows how the same out-of-phase results could be obtained if one of the transmission cables were shorter by one-half wavelength. Actually, the cable would not have to be just one-half wavelength shorter; any "odd-half" shorter such as  $1/2$ ,  $3/2$ ,  $5/2$ ,  $7/2$ , etc., would also cause the signal to be out-of-phase.

To be in phase the cables don't have to be the exact same length. They can be of different lengths but they must differ by multiples of a full wavelength — for example: one full wavelength, two full wavelengths, three full wavelengths, etc. When both transmission cables are at the proper length, the current flowing in cable "A" will arrive at dipole "A" at the same time in the wave cycle that the current flowing in cable "B" arrives at dipole "B." Since there is one cycle per wavelength — the currents arrive at the dipoles at the same time or they differ by a multiple of one full wavelength or cycle — the currents are said to arrive "in phase." As a result, the signals radiated from the dipoles will start out together, or in-phase.

Figure 1-7d shows the third way that the signals from dipoles "A" and "B" can be out of phase.

For purposes of simplicity, it is assumed that the inner conductor of cable "A" connects to the upper half of dipole "A" while the outer conductor of cable "A" connects to the lower half of dipole "A". In this example, cable "B" is the same length as cable "A"; however, the connections on cable "B" are reversed — that is, the inner conductor of cable "B" is connected to the lower half of dipole "B" while the outer conductor is



connected to the upper half of dipole "B". This is exactly opposite from the connections made in cable "A".

Because of these mismatched cable-to-dipole connections, when the current in "A" goes positive on the upper half of dipole "A", the current in the upper half of dipole "B" goes negative; and vice versa for the lower half of each dipole.

As a result, as far as point "X" is concerned, the two signals cancel each other because they arrive out-of-phase.

To summarize, the three most common ways that radiation gets out of phase with respect to a distant antenna and receiver are:

- (1) Dipole radiators are displaced in distance;
- (2) Feed cables are not of equal lengths or in multiples of a full wavelength;
- (3) Dipole radiators are not connected to the feed cables in the same way.

## Aperture

As the aperture or opening size of a valve controls the amount of water that flows through a pipe, the aperture or beam width determines the gain of the antenna. The effective aperture actually takes in something more than the physical size. We think of the aperture as the signal surrounding the antenna in all directions and extending out a given distance (such as one-half wavelength) from the sides and ends. Therefore, it can be said that the aperture is a volume of space.

As an example, a smaller aperture or beam width, say 65 degrees, will have a greater gain than a larger aperture, say 90 degrees. The radiation pattern in the smaller beam width is projected farther forward along the horizontal plane and less along the vertical plane; this results in a higher gain. Conversely, the radiation pattern in the larger beam width has more of the signal projected along the vertical plane and less along the horizontal plane; this results in a lower gain.

## Spacing of Dipole Elements in the Vertical Collinear Array

When a parallel feed system is used — that is, each dipole element in the array is fed by a separate coaxial cable — it is possible to vertically separate the dipoles to obtain an overall



aperture that will give maximum gain. This separation is generally somewhat less than one wavelength between centers.

As the dipoles are spaced closer together, the gain falls off because the coupling between the ends cancels some of the effective radiation.

### **Feeding the Collinear Array**

In a collinear array of two or more dipoles, the two most common means of feeding the power from the coaxial transmission line to the individual dipoles are by (1) series feed, and (2) parallel or shunt feed.

In series feed, the power flows up through a single cable to the first dipole, then to the second dipole, then to the third, etc. In this arrangement, the top dipoles are being fed considerably less power than the bottom dipoles; as a result, the top dipoles do not contribute as much to the gain of the array. Furthermore, this arrangement tends to tilt the lobe of the array off the horizon, further decreasing the gain. Therefore, the number of dipoles that can be fed in series reaches a limit.

Parallel or shunt feed is generally accomplished by running a separate feed cable to each dipole. Then, using matching transformers and junctions, the cables are connected to the transmission line that runs down the tower. This allows the array to be fed in the center. In this arrangement, beam tilt is avoided because essentially equal amounts of power can be delivered to each dipole. In addition, each dipole is virtually as effective as the others since they all receive similar power input.

Whether series or parallel feeding is used, approximately the same gain can be obtained in the same physical length or aperture of the array.

This brings us to the conclusion that with proper design — and we must emphasize proper design — the effective gain of a collinear array is dependent upon the aperture; and this, in turn, is largely dependent upon the physical length of the array.

### **Maximum Gain from a Collinear Array**

Since two-way systems always seem to require more and more range, and since the antenna seems to be a good way

to get this increased range, it would also seem that we could stack as many dipoles as our tower would hold, thereby getting the most signal out of our array. As good as this may sound, there is obviously a physical and economic end to this approach.

First of all, the United States Federal Communications Commission (the FCC) says that if an antenna structure extends more than 20 feet above the top of a tower, building, water tank, etc., it must have lighting on the tower to alert aircraft to its presence. This implies that the support structure must be strong enough to support the antennas and the lights, and it must have climbing steps to access the lights for maintenance.

From an economic standpoint, this pretty much rules out antennas that extend more than 20 feet above the top of a tower. Therefore, given these constraints, the gain of an omnidirectional, top-mounted antenna is limited to approximately 6 dB at 150 MHz or 10 dB at 450 MHz. (You'll note we said omnidirectional. It's actually possible to obtain greater gain with a directional array.)

In the 25-50 MHz band, specially designed dipoles can be mounted on the side of a tower to obtain an omnidirectional pattern. These antennas would have cross-sectional dimensions in the order of one-eighth wavelength or less. On tall towers measuring several hundred feet, up to six dipoles can be "stagger-mounted" down the tower. Mounted on opposite corners or faces of the tower, results can be achieved which approach the collinear gain antennas at 150 and 450 MHz.

### **Directional Gain Antennas**

We've talked about omnidirectional gain antennas or vertical collinear arrays. These antennas have a circular, horizontal pattern. We have also stated that they achieve gain by compressing the vertical pattern down to the horizon using a vertically stacked, collinear dipole array. Now, let's consider antennas that primarily shape the horizontal pattern to achieve gain.

Perhaps it would be wise to remember that antenna gain is simply a matter of reshaping the radiation pattern. We can't generate additional power in the antenna since all we have to work with is what the transmitter gives us.





### **The Dipole and Reflector**

If you will remember, a vertical half-wave dipole has a circular horizontal pattern. If we place it in front of a screen made of metal or wire mesh (see Figure 1-8) it is evident that radiation going to the rear will be blocked. If this blocked radiation is redirected, the resulting pattern will no longer be circular.

We know from theory and experiment that if the dipole is spaced a quarter wavelength in front of the reflecting screen, the radiation that would normally go to the rear is redirected to the front to form a directional lobe — hence a directional antenna. Also, the larger the screen (to a point) the narrower the directional lobe becomes. In this arrangement, we can say the antenna has narrowed its beam width or increased its gain. In effect, then, the dipole serves to “illuminate” the screen, with the screen radiating on transmit and collecting on receive.

### **The Corner Reflector and Parabolic Reflector**

If an antenna's reflecting screen is formed into a right angle or a “V” of the proper size, and if the dipole is located a certain distance from the screen angle intersection, the antenna becomes a corner reflector directional antenna (see Figure 1-8). The beam width and gain will depend upon the relationship of the screen size, the angle of the screen, and the dipole position. The screen also can be formed into a parabolic type reflector with the dipole at the focal point (see Figure 1-8).

To reduce wind drag, instead of making reflectors from wire mesh screen or solid metal, we can use closely spaced vertical rods (see Figure 1-8). The use of vertical rods also makes for a more rugged structure.

### **The Yagi Antenna**

Perhaps the most widely used directional gain antenna is the Yagi. The Yagi has many forms and variations but generally it consists of at least two elements, and more often, three elements (see Figure 1-9).

The basic components of the three-element array are: a radiator, a reflector, and a director. These three components are typically arranged such that the director element is in the front, the radiator is behind the director, and the reflector is



behind the radiator. In general, the director element is the shortest element while the reflector is the longest. The length of the elements and the distances between them determine the radiated power that goes into a directional lobe. Thus, these factors ultimately determine the Yagi's gain.

Due to its high gain, low weight, low wind drag, and its relatively low cost, the Yagi antenna is considered to be well-suited for use in two-way radio communications.

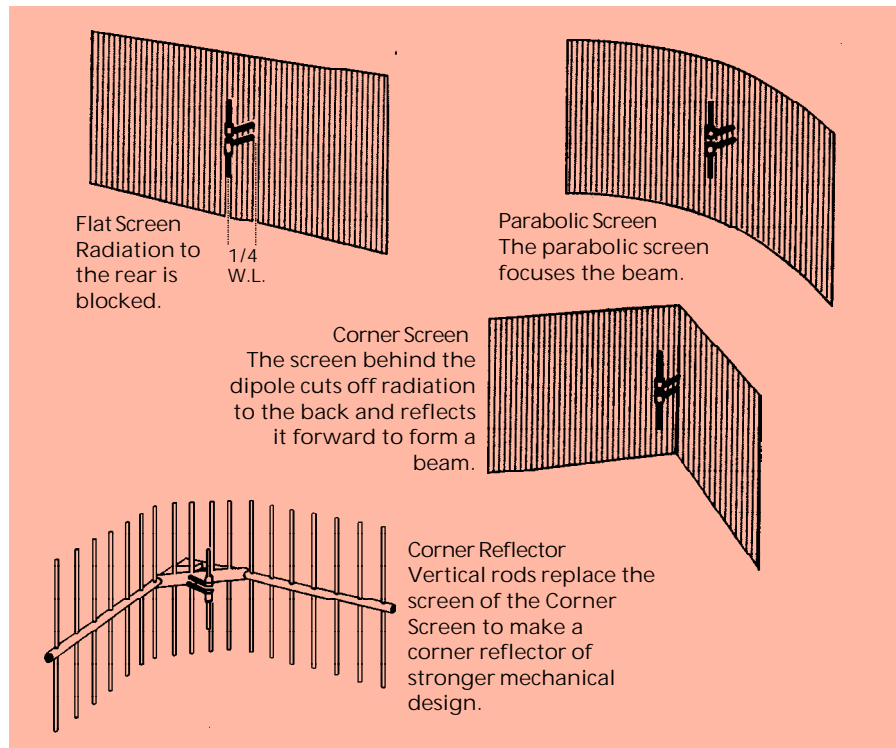

Figure 1-8: The Omnidirectional Pattern of a Dipole can be made Directional

### How Many Elements?

To increase the gain of the three-element Yagi, we can add additional directors in front of the first director but, from a practical standpoint, there is a limit to this arrangement. For example, to increase the gain by 3 dB, we could add directors of the proper length and spacing, but doing so would effectively double the overall length of the antenna. Obviously, this will impose size limitations, especially at low frequencies. Fur-

thermore, for applications where the antenna must operate on multiple frequencies, the additional elements narrow the band width and make it less useful.

Another way to increase the directivity or the gain of a Yagi antenna is to position two antennas side by side. This is done by determining the proper spacing between the antennas, attaching them to a horizontal support bar, then, mounting the support bar to the tower. This has the advantage of bringing the center of the antenna array into the mounting mast or tower. This is especially important in the 30-50 MHz band.

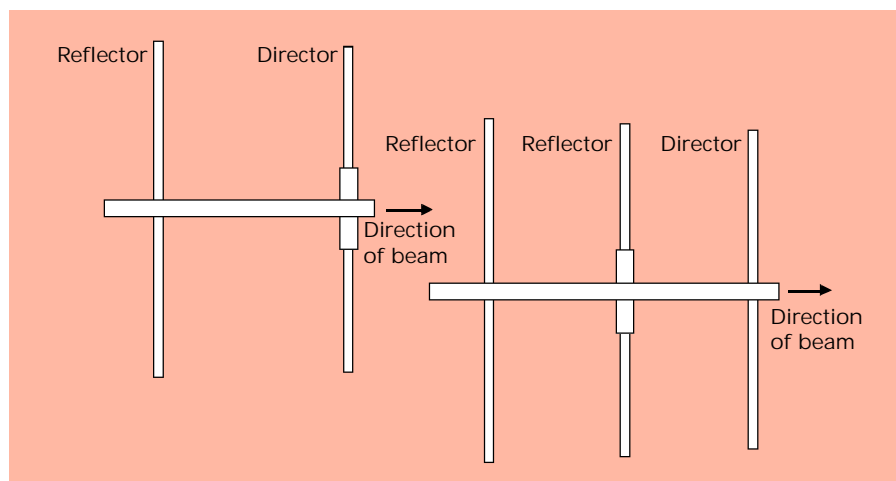

Figure 1-9: A Two-Element and Three-Element Yagi Directional Antenna

### **Phased Radiators for Directivity**

In our discussion of in-phase and out-of-phase conditions of base station gain antennas, we said that when Observer "X" (see Figure 1-7) was positioned an equal distance from two radiators, the transmitted currents would add up in-phase and increase the gain. But, when Observer "X" was positioned where there was a difference of one-half wavelength between the radiators, the currents canceled each other. This principle is often used to form directional arrays whereby two or more vertical radiators are spaced apart horizontally and fed power so as to produce a directional pattern.

### A Bidirectional Array or Figure-Eight Pattern

A bidirectional, figure-eight pattern can be formed from two radiators that are spaced one-half wavelength apart and fed in phase. Looking at Figure 1-10, it can be seen that along the line "AB" the radiators will be equal distances. Therefore, the radiation from them will arrive along this line at the same time, or in-phase, to produce an increase.

Along line "CD", however, there is a difference of one-half wavelength, which is out-of-phase. The radiation along this line will cancel and make a null. The resultant pattern, therefore, is a figure-eight.

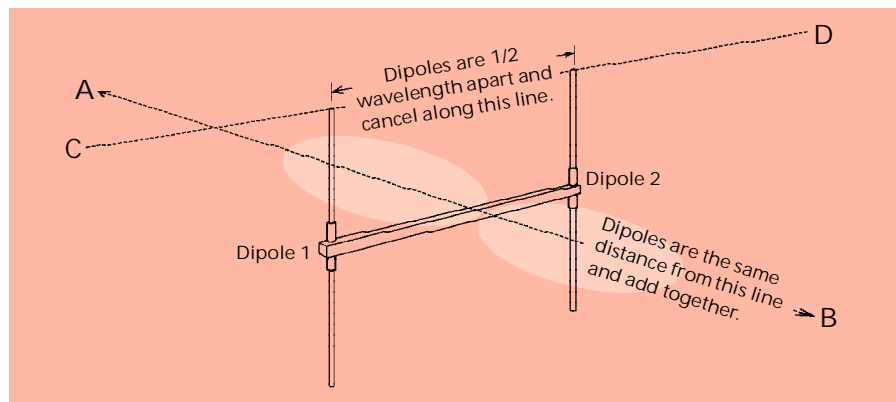

Figure 1-10: This figure illustrates how two dipoles spaced horizontally apart by  $1/2$  wavelength and fed in phase, produce a "Figure 8" bidirectional pattern.

### Additional Gain by Stacking Directional Antennas

Since directional gain antennas obtain gain primarily by compressing the horizontal pattern, it becomes evident that additional gain can be obtained by stacking such antennas in a vertical line as we did with the omnidirectional collinear gain antennas. The net effect, then, is to compress both the horizontal and vertical patterns.

This double compression gives optimum utilization of the power in a certain direction where maximum gain is desired. Of course, they must be phased together correctly and matched to the transmission line to achieve maximum gain.

There is also the limitation of practical size. To obtain an extra 3 dB gain, the number of elements (or size) must be doubled, and doing this soon makes the antenna array too big to be practical.

Again, it must be remembered that the effective above-ground height of the antenna is to the center of the array. Therefore, in the 30-50 MHz band, where the antennas are typically quite large, stacking additional elements may not improve performance unless the tower is tall enough to accommodate them.

### **Side Mounted Antennas**

Many directional antennas, and so-called omnidirectional antennas, are mounted on the sides of towers. For the directional antenna this poses no problem. Since the radiation is directed out from the tower, the tower has little effect upon the pattern or gain. This is not true with antennas designed for omnidirectional patterns because the tower will become "excited" by the currents radiated into it. This will cause the radiation to be redirected in a directional pattern.

### **Then How Do We Get an Omni Pattern?**

When an omnidirectional pattern is desired from a side-mounted antenna, two or more radiators of proper design can be placed around the tower in a manner that will prevent severe cancellation between the radiators.

This is practical in the 30-50 MHz band through the use of a folded dipole radiator. When placed on opposite sides of a tower where the horizontal displacement distance between the two radiators is no more than  $3/16$  wavelength, the pattern will essentially be omnidirectional. By stacking the radiators apart vertically the effective aperture of the antenna is increased and gain is obtained. On towers that are tall enough, additional gain may be obtained by adding radiators, provided the radiators are positioned properly and matched to the transmission line.

Limitations in this arrangement include: a tower that isn't tall enough to be effective, signal loss in the extra connecting cables, and the costs associated with the additional antenna(s).

### **Noise**

We mentioned earlier that the only reason an antenna seems to operate differently on receive versus transmit is the noise factor. Effectively, where base station noise exists at fairly

high levels compared with the noise level at the mobile unit, it will make the antenna appear to be inferior when receiving versus when it is transmitting. On the other hand, if the noise level at the base station is low compared to the mobile location, it will make the antenna appear superior when receiving versus when it is transmitting.

### **What Do We Mean by Noise?**

When receiving, an antenna is a collector. It collects not only the desired signal but, because it can't differentiate between a valid signal and noise signals, it collects any noise signals that fall within its pattern and bandwidth. It cannot discriminate or select. Furthermore, since the antenna is much less selective than cavity filters or receivers, it collects noise over a fairly broad frequency range.

### **What Happens to Noise with Gain?**

Sometimes, when a unity-gain (0 dB) omnidirectional antenna is replaced with a high-gain directional antenna the performance does not meet expectations when receiving. When the higher gain antenna compresses the vertical pattern, the noise level often increases along with the increased gain. In terms of signal-to-noise improvement, the resulting improvement in gain is not as apparent upon receive as it is upon transmit. This is especially true in the 30-50 MHz and the 148-174 MHz bands in metropolitan or industrial areas.

Directional gain antennas could hurt or help the situation, depending upon whether the directive beam looks into or away from an area of high noise. For example, if a 40 MHz directional antenna looks out across a busy metropolitan area, it will likely show poor performance upon receive. However, if it's turned away from the city and directed toward a residential or rural area, it may show an improvement in reception that is greater than its gain. This would be due to its front-to-back ratio being used to discriminate against the noise and improve the desired signal.

A gain antenna is like a telescope: it effectively brings the noise source closer. This fact must be considered when locating a high gain antenna, especially one in the 30-50 MHz and 150 MHz bands.



### **What About the 450 MHz Band?**

There's noise at 450 MHz, but it's greatly reduced from that of the 150 MHz and 40 MHz bands. It must be remembered that noise is actually a combination of many smaller noises. Principally, among these are man-made noises such as automobile and truck ignitions, electric power distribution lines, and electrical machinery. These noises are much stronger in the 30-50 MHz band; there is a considerable reduction at 150 MHz, and even further reduction at 450 MHz.

### **What About the Countryside?**

Noise prevails not only in the city and industrial areas but often in rural areas far removed from the freeways and the electrical machinery. Generally, the offender is a relatively low voltage electric power system used in supplying power to farms. The type of construction used in the power system and the lack of a suitable earth ground can play havoc with a nearby receiver.

A similar condition can exist along sea coasts where power line insulators have become encrusted with salt deposits. This results in corona and voltage breakdowns across the insulators on the high voltage power lines. Fortunately, a good rain can often clear up this condition.

Noise is a great problem and careful surveys should be made when low noise is essential to a system's performance — especially where high gain antennas are used. Also, noise blankers can be quite effective against impulse noise from auto ignition systems, but they are less effective against power line noise.

### **Bandwidth**

There's one more thing about antennas that we should consider: bandwidth. Earlier in our discussion, we stated that an antenna had to be resonant at the operating frequency to work properly. We also stated that to be resonant, it had to be cut to the right length. While these statements are true, it could be a real bother if it were strictly true down to the last hertz.

Actually, almost every antenna has a little bit of bandwidth. That is, even if it is cut and tuned to a particular frequency, it will operate well at several hundred kilohertz, and perhaps

even a megahertz, above or below the tuned frequency — or at least so well you couldn't tell the difference.

By designing an antenna with a bandwidth in mind, depending upon the frequency band, some types of antennas can be made to operate equally well over a broad range — 15 to 20 megahertz, for example. These are the ones we refer to as broadband antennas.

While there's a lot more to antenna design than we've covered in this section, we'd like to emphasize is that there's no magic in antenna design — there aren't any electron magnets, wave concentrators, or signal intensifiers. An antenna is a passive device; it can only radiate the power sent to it from the transmitter or furnish the receiver with energy it collects from the air. But, with a minimum efficiency of 96 percent, it does a remarkable job of these two functions.







# Combiners

The need for combiners has long been known and their recognized importance continues to grow at an accelerated rate. More and more land mobile radio systems are being equipped for simultaneous operation on several frequencies from a common site, and a combiner can eliminate the need for separate antennas for each radio system. In addition to reducing the number of antennas, better performance can usually be realized if the highest antenna site is selected and used with the optimum combiner.

A single "master" antenna and its transmission line can be shared by two or more transmitters, receivers, or simplex base stations by connecting them to the antenna through a combiner. Sharing of a single antenna is not limited to a single system operator. When several base stations, operated by different users, are located at the same site, they can often share a common antenna, depending upon the frequencies used.

Most radio systems that operate at a common site and utilize independent antennas and transmission lines will require multiple interference protective devices. These usually are ferrite isolators for reducing transmitter intermodulation to an acceptable level, bandpass or band-reject cavity filters (installed between transmitters and antenna) for reduction of transmitter noise, and bandpass or band-reject cavity filters for protection against receiver desensitization from transmitter carrier frequencies. These devices introduce losses to transmitter power and received signal strength. If interference-free ra-



dio systems are to be achieved, these losses can approach those of a combiner and yet not afford an optimum “RF clean” antenna site.

### **Combiner Requirements**

A combiner that enables the use of a common antenna by two or more transmitters should cause a minimum of insertion loss (transmitter power loss) and should provide a high degree of isolation between the transmitters. This ensures that potential transmitter-produced intermodulation frequencies are minimized.

Transmitter intermodulation is the primary factor that must be considered when two or more transmitters are combined into a common antenna. In addition to the above, a combiner that enables a number of transmitters and receivers to use a common antenna must also ensure that any receiver desensitization caused by the transmitters and any transmitter noise at the various receiver frequencies are reduced to an acceptable level.

When the transmitters and receivers share a common antenna through a combiner, the only practical method of protection for transmitter noise and receiver desensitization is by use of resonant cavity filters between the transmitters and receivers. Should the frequencies be separated by a reasonable amount, a simple cavity-filter-combiner configuration can be used for two or more systems — the radio manufacturer’s duplex operation curves can provide the proper isolation required for any given frequency separation. If the transmitter frequencies are extremely close, the hybrid/ferrite isolator combiner is normally used.

### **Cavity Type Combiners**

The cavity-type combiner is one of the most common combiners used to couple transmitters and/or receivers into a single antenna. This type of combiner is generally more economical and affords less insertion loss than hybrid/ferrite combiners. It is normally used when the channels to be combined have a frequency separation of at least 150 KHz in the low band, 500 KHz in the 150 MHz band, and 1 MHz in the 450 MHz band.

Also, as mentioned previously, if the systems to be combined contain receivers, cavities must be used since hybrid/ferrite combiners have unidirectional devices (isolators) as components.

The cavity-type combiners can be composed of all bandpass cavities, all notch (band-reject) cavities, or a combination of bandpass and notch cavities.

### All Bandpass Combiners

The bandpass combiner is used when a fixed number of stations with a relatively wide frequency separation are combined into a single antenna. Figure 2-1 shows a block diagram of a bandpass combiner. Two transmitters and two receivers are combined into a single antenna through the use of bandpass cavities and a five-way connector. The bandpass cavities in the transmitter lines protect the receivers from transmitter sideband noise radiation by attenuating the output of the transmitters at the receiver frequencies. Those in the transmitter lines also mutually isolate the transmitters, thereby reducing the possibility of transmitter intermodulation. The bandpass cavities in the receiver lines protect the receivers from receiver desensitization by attenuating the transmitter carriers before they reach the receivers.

The number of cavities in each combiner system is dependent upon the frequency separation between the systems. In Figure 2-1, if the frequencies were closer together, four or possibly five bandpass cavity filters would be needed to mutually isolate the systems. The length of the interconnect transmis-

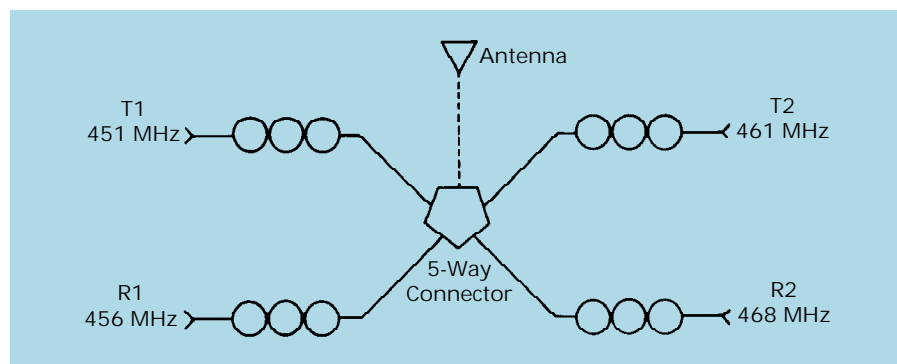

Figure 2-1: All Bandpass Combiner

sion line from the cavity to the five-port junction is electrically an odd quarter-wave length (including the electrical length of the cavity coupling loop). This is so the other three frequencies are presented a high impedance (open circuit) at the five-port junction. Consequently, very little coupling loss is added to the insertion loss of the triple bandpass cavity for each frequency.

The number of systems in this type of combiner is not limited to four. The limitation as to the number of systems depends upon the frequency separation between the systems, the bandwidth of the antenna, and the maximum insertion loss that can be tolerated. The all-bandpass combiner is best used when the frequency separation between systems is at least 500 KHz in the low band, 1 MHz in the 150 MHz band, 2 MHz in the 450 MHz band, and approximately 5 MHz in the 806-960 MHz frequency band.

The main advantage of an all-bandpass cavity combiner is the added protection the receivers obtain from the carriers of other transmitters in the area, as well as from those in the combiner. Likewise, the bandpass cavities in the combiner provide added protection against transmitter noise to other receivers in the area and to those in the combiner.

Compared to hybrid-type combiners, the bandpass-type generally has lower insertion loss per channel. The disadvantages include its relatively large physical size, its inability to operate satisfactorily at very close frequency spacings, and the fact that the combiner is not readily expandable to accommodate more systems.

### **Notch Filter Combiner**

The all-notch filter combiner is used normally when the frequency separation is too close for band pass filters, yet is still wide enough that ferrite isolators are not needed. This type of combiner is sometimes used, especially when only two systems are combined. When two closely-spaced systems are to be combined, the simplest device to use is a standard band-reject type duplexer. The standard band-reject duplexer can combine two transmitters or two simplex systems to a common antenna. In addition, the normal duplex transmitter and receiver can be combined to a common antenna.

The block diagram in Figure 2-2 shows three systems coupled by use of a notch filter combiner. Note that the frequency separations are 540 KHz and 615 KHz in the VHF band. Each system is mutually protected from the other by a series of two cavity-notch filters having about 50 dB isolation. The insertion loss of each system measured at the antenna port (output) is approximately 2.5 dB.

The addition of another system to the above example is possible but economically impractical since the number of cavities would nearly double. The reason for this is that each system must be protected from the new system, while the new system needs protection from the existing systems. Doing this would add eight more cavities to the setup. Because of this, the band-reject type combiner is best suited for combining two or three, but rarely four, systems.

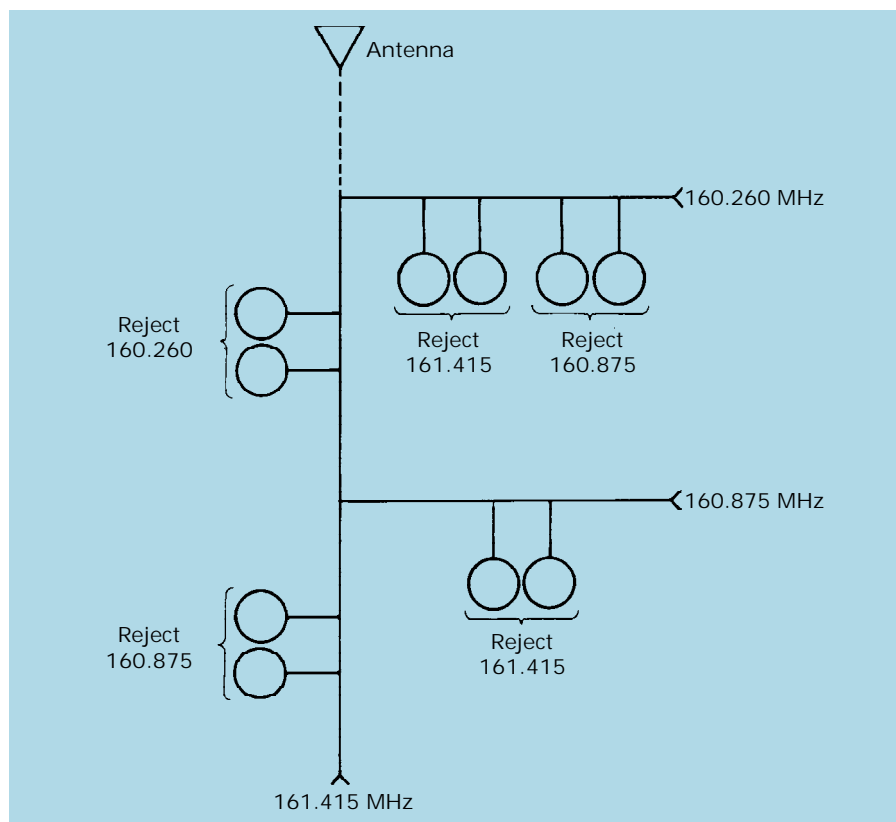

Figure 2-2: Notch Filter Combiner

The advantage of the band reject combiner is its use in combining systems with close frequency separations. These minimum separations are approximately 150 KHz in the low band, 500 KHz in the 150 MHz band, and 1 MHz in the 450 MHz band. An important disadvantage is its lack of interference protection from other systems located nearby.

### Bandpass-Notch Combiners

The bandpass-notch class of cavity-type combiners uses the combination of bandpass and notch filters to allow many transmitters and/or receivers to be used with a single antenna. This is a modular-type system in that each channel consists of a bandpass filter and a notch filter, as shown in Figure 2-3.

The purpose of the bandpass filter is to isolate the system from others in the multicoupler while the notch filter is used

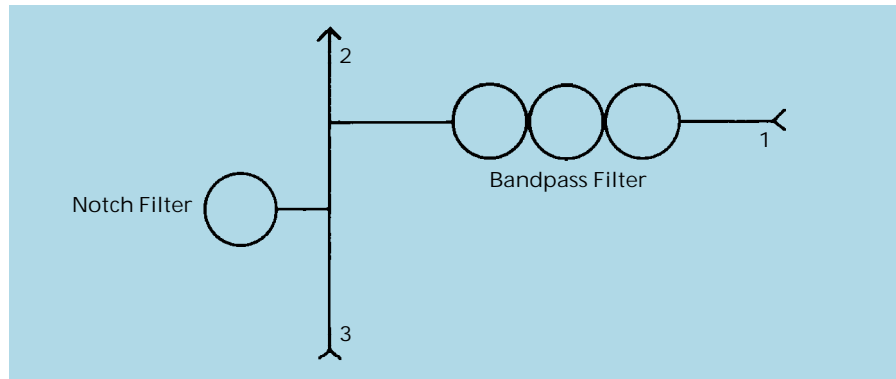

Figure 2-3: Bandpass - Notch Module

mainly for matching the input terminal to the output — i.e., low insertion loss from port 1 to port 2 and vice versa. The number of cavities in the bandpass filter will be dependent upon the frequency separation between the systems and the maximum insertion loss that can be tolerated.

Figure 2-4 shows how these “modules” fit together to make a four-system combiner. The last system does not need a notch filter for matching since it is the terminal system. However, if another system were to be added at a later date, a band-reject filter for system number four would be needed.

The bandpass-notch combiner should be used when a

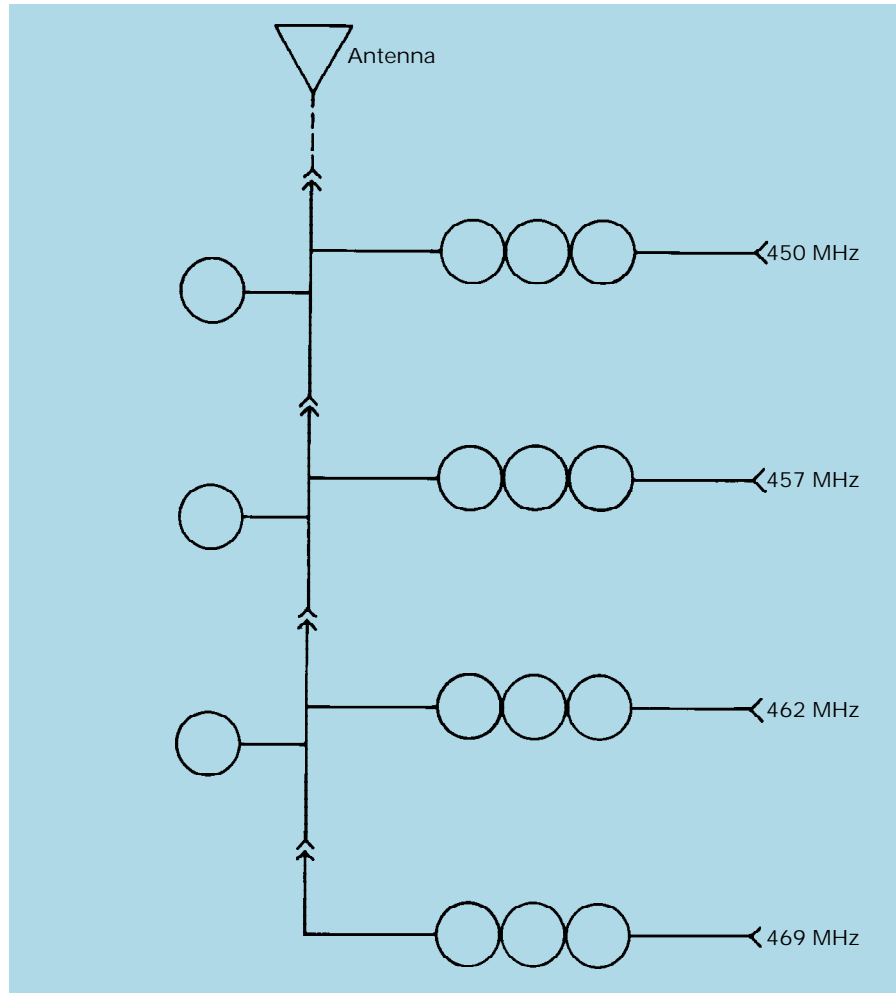

Figure 2-4: Bandpass / Notch Combiner

readily expandable system is needed and the minimum frequency separations are approximately 500 KHz in the low band, 1 MHz in the 150 MHz band, 2 MHz in the 450 MHz band, and 5 MHz in the 806-960 MHz band.

Like the all-bandpass combiner, the bandpass-notch combiner has the advantage of added interference protection from other systems in the immediate area. Its disadvantages include its relatively large physical size and its inability to operate satisfactorily at very close frequency spacings.



### Transmitter Intermodulation

The all-bandpass combiner offers excellent protection for transmitter noise and receiver desensitization. But what about transmitter intermodulation products and/or receiver intermodulation products? As we stated earlier, transmitter IM is the primary factor that must be considered when two or more transmitters are combined into a single antenna.

All intermodulation effects produced by mixing the non-linear outputs of either transmitter, or the non-linear input stages of the receiver, are a function of the frequency difference between the combined frequencies for any number of sums and the differences of the fundamental frequencies and their harmonics. This is illustrated for the familiar third and fifth order intermodulation products in Figure 2-5.

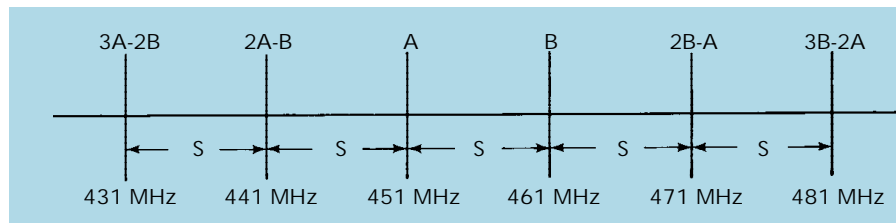

Figure 2-5: Intermodulation Frequencies

### Typical System Analysis

The following example illustrates the third order intermodulation protection provided by the all-bandpass combiner represented in Figure 2-5: "A" is frequency T1, "B" is frequency T2, and their frequency difference is "S." Third order intermodulation frequencies "2A-B" and "2B-A" and fifth order "3A-2B" and "3B-2A" are depicted. There are an infinite number of intermodulation frequencies having a frequency difference of "S." However, normally only the third order products are of sufficient power levels to cause interference problems.

The attenuation to each intermodulation product by the triple bandpass cavities can be determined from the cavity response curves. The energy coupled into transmitter "A" from transmitter "B" is attenuated approximately 70 dB (a 10 MHz difference) by the cavities; likewise, this is also true from transmitter B into transmitter A. After mixing in the non-linear output of transmitter A or B, the third order intermodulation product, being 20 MHz off resonance of the cavities, is attenuated

by more than 70 dB. Consequently, the third order intermodulation products are greater than 140 dB below the transmitter carrier(s) — a most insignificant level.

However, suppose this is not the only system at this location. Further, suppose another 9 dBd gain antenna radiating 250 watts, at a frequency two channels higher, is located horizontally from our system's 9 dBd gain antenna, as shown in Figure 2-6.

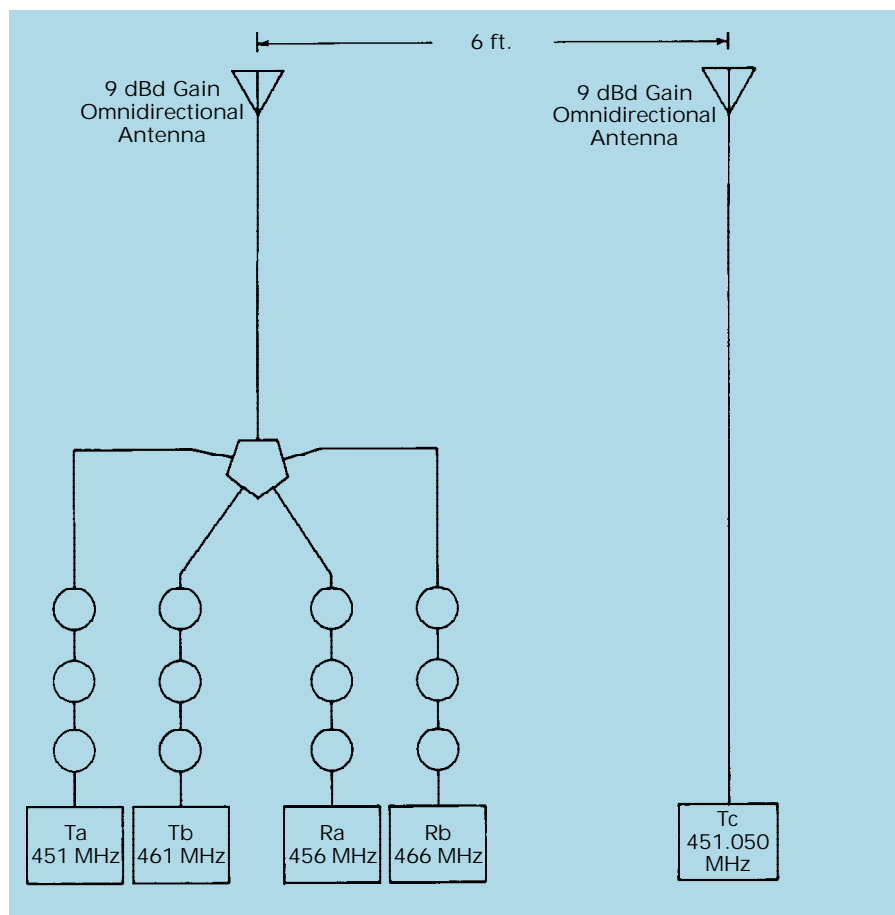

Figure 2-6: Close Coupled Systems with 3rd Order Intermodulation Emission

The frequency difference being 50 KHz, the transmitter carrier frequency from transmitter C into A is attenuated essentially only by the space coupling loss between the anten-

nas and transmission line loss. The cavities offer practically no attenuation other than the insertion loss at this frequency separation.

Let us determine the approximate power of the radiated third order intermodulation frequency from transmitter A:

**Coupling loss:**

Antenna space coupling loss = -25 dB (Antenna 1 to 2)  
Transmission line loss = -1 dB (Transmitter A and B)  
Cavity loss at +50 KHz = -2.5 dB (A)  
Total = -28.5 dB

**Third Order Intermodulation Product radiated from A:**

Transmitter Power (250 watts) = +24 dBw (from C)  
Coupling loss = -28.5 dB (C to A)  
Power in final (Tx A) = -4.5 dBw  
Transmitter conversion loss = -6.0 dB (assumed)  
Cavity loss at +100 KHz = -3.0 dB  
Antenna gain = +9.0 dB (Antenna A)  
Transmission line loss = -1.0 dB (A)  
ERP of IM product = -5.5 dBw or 0.28 watts (reference to half-wave dipole)



This radiated power could be a problem to a mobile system that might be in the vicinity of the antenna site. It could easily occur if our site were a building roof top.

**The Ferrite Isolator**

The ferrite single junction isolator (see Figure 2-7) is a three-port circulator (see Figure 2-8) with a matched resistive load connected to port 3. The ferrite circulator is a three-port, non-reciprocal device consisting of ferrite material, magnets, and three short lengths of transmission line terminated at a common junction. The basic ferrite material commonly used is an oxide of yttrium iron garnet (YIG) commonly called garnet. The garnet is cut to the proper shape in a manner similar to the crystals used in the two-way radio. The proper combination of incident RF field and DC magnetic field cause what is called "gyromagnetic resonance." For one direction the response is dispersion and resonance absorption, whereas the

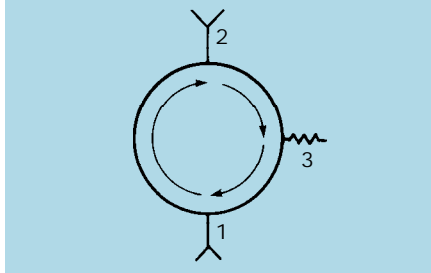

Figure 2-7: Ferrite Isolator

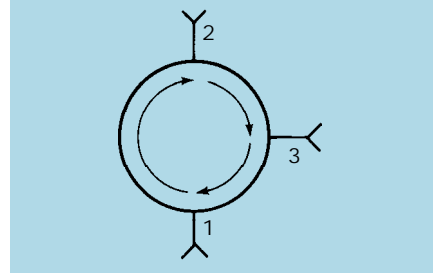

Figure 2-8: Ferrite Circulator

response for the opposite direction is flat. It is from these opposite effects that isolation is permitted between the ports of the circulator. Power entering port 1 is “rotated” and emerges at port 2. Power entering at port 2 emerges at port 3 and is absorbed by the resistive load. The load at port 3 should always be of an adequate wattage rating to absorb the maximum expected reflected power from the subsequent antenna system.

The ferrite isolator is the most effective solution to transmitter-produced intermodulation when the frequency separation between the transmitter frequencies is as close as adjacent channels. When installed between the transmitter and subsequent combining network, or between the transmitter and antenna, the ferrite isolator acts like an RF diode. It passes transmitter power from its input (port 1) to its output (port 2) with very little loss — perhaps  $-0.5$  dB — but attenuates energy in the opposite direction by 25 to 30 dB for the single stage isolator.

### Low-Loss Type Transmitter Combiner

To prevent radiation of transmitter intermodulation from our all-bandpass cavity combiner of Figure 2-6, we can add a pair of tunable ferrite isolators to each transmitter leg as shown in Figure 2-9. The coupling loss of Figure 2-9 is now increased by an additional 60 dB, and, with this added insertion loss, the power radiated by the third order intermodulation frequency is 0.28 microwatts — an insignificant amount.

It must be pointed out that the ferrite isolators must also be in transmitter C of Figure 2-9 if we are to reduce intermodulation products from transmitter C due to transmitters A and B.

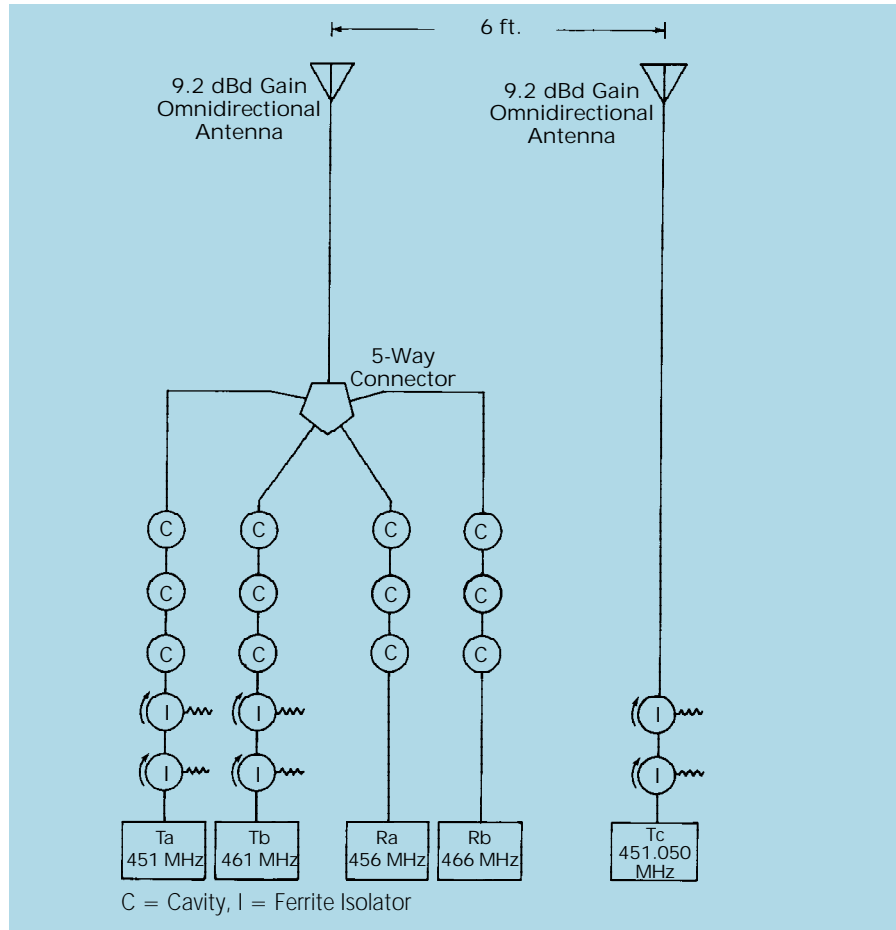

Figure 2-9: Close Coupled system with Ferrite Isolators

### Low-Loss Transmitter Combiner For Close Frequency Spacing

Utilizing extremely high  $Q$  bandpass cavities and ferrite isolators, the all-bandpass combiner shown in Figure 2-1 can be used for extremely close transmitter frequency separations. A four-channel low-loss transmitter combiner is shown schematically by the block diagram in Figure 2-10.

The primary function of the high  $Q$  cavity is to match the impedance at the junction so the signal from each transmitter passes through the junction to the antenna at a minimum loss. The higher the cavity  $Q$  — or the greater the cavity selec-

tivity — the closer the frequency separation between channels can be and still maintain low insertion loss per channel.

In an extremely high Q coaxial cavity the input impedance rapidly approaches a low impedance as the frequency moves off resonance. In the 150 MHz frequency band, the impedance at 60 KHz off resonance is low enough that by using the proper length of cable between the cavity and the N-way junction (a quarter-wavelength less the electrical length of the coupling loop) a high impedance is presented at the junction. This allows all of the signals from the other transmitters to pass through the junction at a minimum loss.

A definite advantage that the low loss combiner in Figure 2-10 offers is the additional filtering from the high Q cavities in the line. At 5 MHz from the transmitter frequencies — where the receiver frequencies usually fall in the UHF band — transmitter noise and spurious responses are usually reduced at least 50 dB from the output of the transmitter.

The low loss type combiner in Figure 2-10 is expandable to a 5-, 6-, 7-, or 8-channel unit. The loss through the combiner does not appreciably increase unless the frequency separation between channels is decreased.

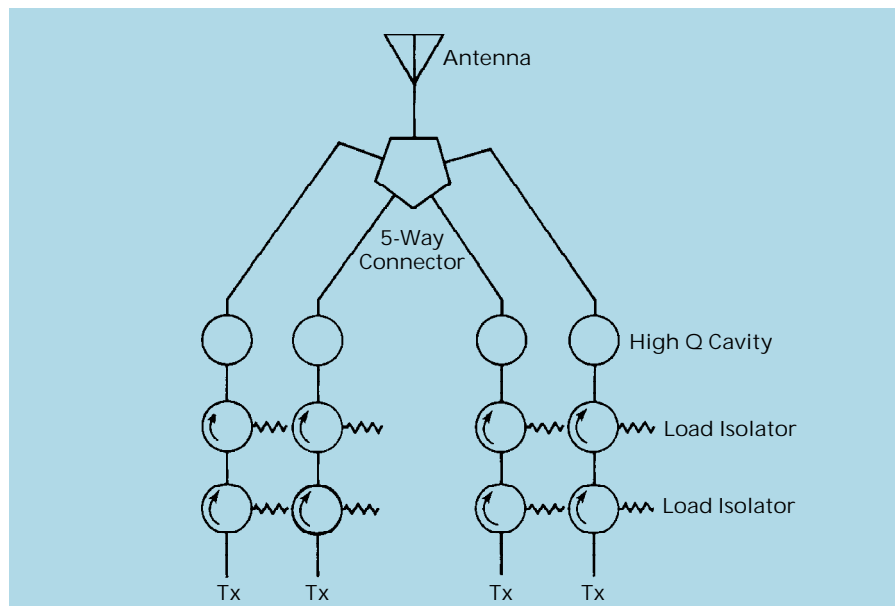

Figure 2-10: Block diagram of Low-Loss, Four-Transmitter Combiner

### The Hybrid Coupler

Figure 2-11 represents a four-port, stripline, 3 dB directional coupler. When the hybrid is properly terminated with matched loads, isolation is provided between ports 1 and 2 of up to 40 dB. Energy entering port 1 and/or port 2 splits with half going to port 3 and half to port 4. Consequently, the termination at port 3 must be able to absorb half of each transmitter's power.

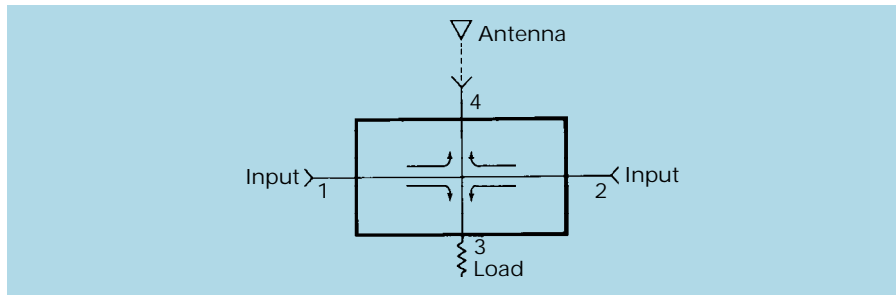

Figure 2-11: 3 dB Stripline Hybrid Coupler

### The Hybrid Combiner

The hybrid two-transmitter combiner illustrated in Figure 2-12 utilizes 3 dB, stripline, hybrid ferrite isolators and low-pass harmonic filters to combine two transmitters. The transmitters should be at adjacent channels or at channels up to a frequency separation determined by the bandwidth of the hybrid and/or ferrite isolators. The harmonic filter is required

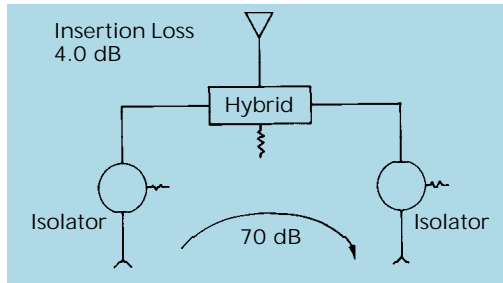
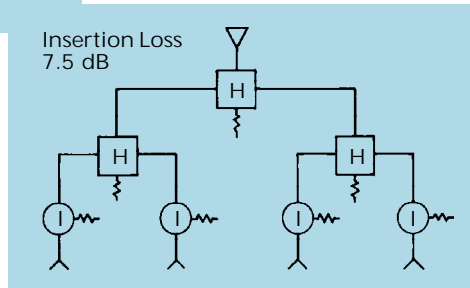

Figure 2-12: Hybrid Two-Transmitter Combiner

Figure 2-13: Hybrid Four-Channel Combiner



because the ferrite isolator may itself produce harmonics. The bandpass cavity rejects harmonic energy in the low-loss type combiner.

The use of additional hybrid couplers and two-transmitter combiners allows expansion to either a four-channel transmitter combiner (see Figure 2-13) or an eight-transmitter combiner (see Figure 2-14). The nominal isolation between transmitters is 65 to 70 dB when a single isolator is used; the nominal isolation can approach 100 dB when two isolators are used per channel. However, as the number of transmitters increase, the insertion loss for each transmitter increases. For example, the two-channel combiner has a loss of approximately 4 dB, the four-channel has a loss of approximately 7.5 dB, and the eight-channel has a loss of approximately 11 dB.

A disadvantage of the hybrid-type combiner — besides the transmitter power loss — is that the isolation of the hybrid is a function of how well the hybrid is matched to the antenna system. An input VSWR of 1.5:1 on the transmission line to the antenna system can cause an isolation loss of up to 25 dB. Most hybrid couplers, however, have built-in circuits to match the 1.5:1 VSWR, thereby maintaining at least a 40 dB isolation.

The main advantage of a ferrite combiner is its ability to isolate and combine any channel assignments within its frequency band. Its relatively small size is another advantageous feature. Multiple channel combiners can be packaged in a standard 19-inch rack.

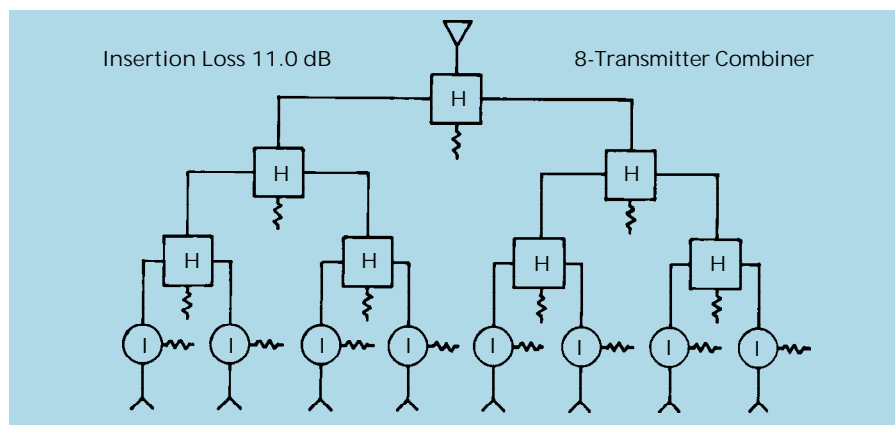

Figure 2-14: Hybrid Eight-Channel Combiner



### The Receiver Multicoupler or Combiners

Normally, each transmitter, unless it is for paging only, has a receiver associated with it. If the transmitters are combined into a single antenna, then logically all the receivers should be coupled from a common antenna.

Usually, the receiver multicoupler for close frequency spacing will consist of a 2, 4, 8, 16, etc., hybrid splitter and an amplifier.

The critical aspects of a receiver multicoupler are the stringent requirements for an active device that has enough gain to recover the splitting losses and yet has an extremely linear gain characteristic. Otherwise, a non-linear mixing stage is present to generate receiver intermodulation which could mask the desired signals.

### A Complete System Configuration

Figure 2-15 depicts a two-channel hybrid-type combiner that is operating through a duplexer with a two-port receiver multicoupler. The criterion with this configuration is that the duplexer should have a bandwidth that will accommodate the required frequencies.

For the combiner to operate efficiently, the transmitter frequencies must be spaced close enough to allow the notch-type duplexer to adequately isolate the transmitters and receivers. That is, the notch width of the duplexer at the re-

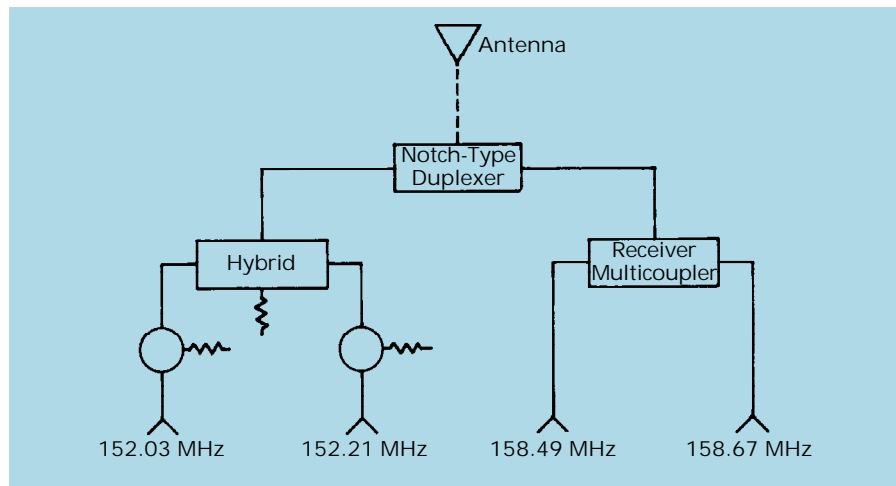

Figure 2-15: Two-Channel Transmitting and Receiving Combining System

quired isolation will dictate the maximum transmitter frequency separation. This criterion also applies to the receiver frequencies.

In many systems — such as the RCC, taxi, and mobile telephone channels — bandwidths up to 600 KHz are needed to combine all or most of the available channels. In cases such as these, the low Q, rack mount, notch-type duplexers are needed in the combiner because their wide notch widths allow adequate isolation across the entire frequency band. Also, a bandpass duplexer would not be practical since a relatively broad band of frequencies are to be “passed” through the duplexer.

### **Combiner Selection**

The optimum type of combiner for a particular system depends upon separation of frequencies, antenna system gain, the number of transmitters and their power output, the number of receivers (if any), the proximity to other systems, and other local factors. A combiner should be designed to meet the requirements of a specific system.





# Selective Cavities

As the demand for land mobile radio services steadily increases, the problems caused by frequency congestion, receiver desensitization and intermodulation, grow rapidly. The selective cavity will help in solving these problems. In this section, we will take a look at selective cavities, how they work and how they can be used.

## **What is a Selective Cavity and What Does it Do?**

A selective cavity is a rather simple device that serves as a filter for radio frequencies. It has the ability to let a narrow band of frequencies pass through while frequencies outside this narrow band are attenuated. Stated differently, the unwanted and unselected frequencies are rejected and filtered out while the desired frequency is passed through with only slight attenuation. The narrow band of frequencies that pass through the cavity are within a few thousand hertz of the cavity's resonant frequency.

The selective cavity, with this "filtering action," is important in the land mobile radio services as more and more new stations are crowded into the same area. As new stations go on the air, they can, and frequently do, cause interference to other stations that exist in the immediate area. In addition, these new stations can receive interference from the existing area stations.

The two most common forms of interference are receiver degradation (which consists of receiver desensitization and/or



### 3-2 About RF COMMUNICATIONS

---

transmitter noise), and intermodulation. Without going into lengthy discussions of these two problems, let it be said that receiver desensitization occurs when a nearby transmitter “overpowers” a receiver. Intermodulation occurs when two or more nearby transmitters “mix” within the RF stages of a receiver and generate new frequencies, with one of the new frequencies being the same as the receiver frequency.

In both cases, a selective cavity can be used to help solve the problem. In the case of transmitter noise, the cavity can be used at the transmitter to reduce transmitter noise sidebands. More specifically, it will increase receiver selectivity and make the receiver less sensitive to nearby transmitters. In the case of intermodulation, the cavity will filter out the unwanted transmissions, thus keeping them from reaching the receiver.

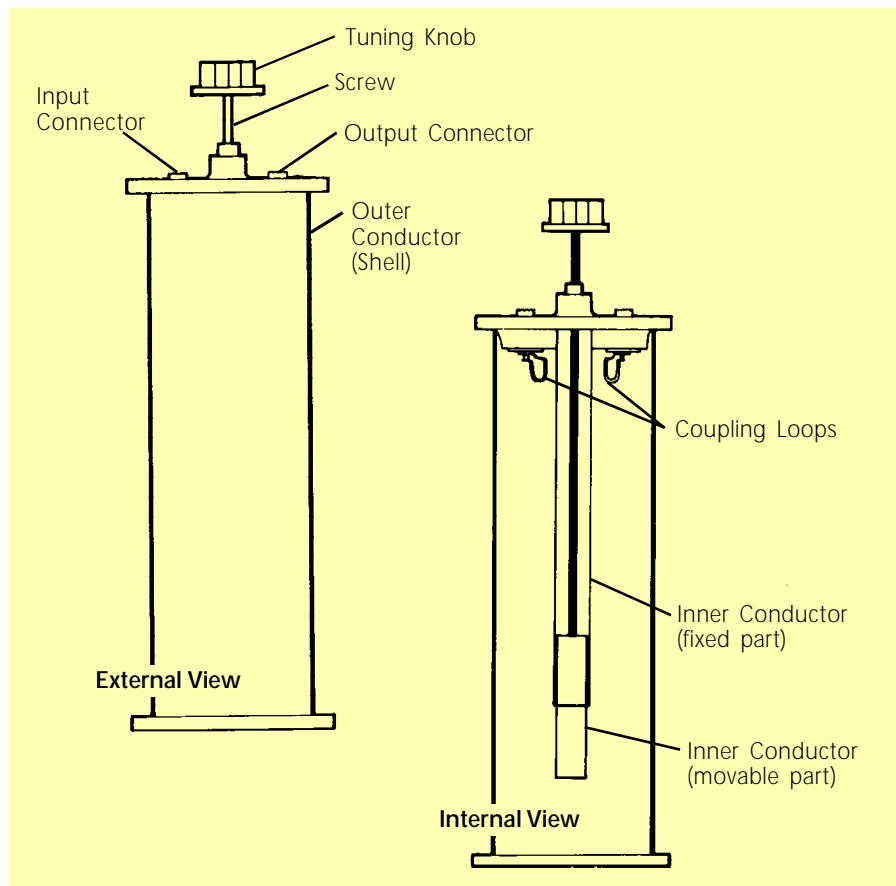

Figure 3-1: The Basic Makeup of a Selective Cavity

### How it Works

As RF energy is fed into the cavity by means of a coupling loop, the energy "excites" the resonant circuit formed by the cavity's inner and outer conductors; the other loop couples energy from the resonant circuit to the output. The resonant circuit is formed by the inner conductor and an equal length of the outer conductor. To change the resonant frequency of the cavity, the length of the inner conductor is changed. Usually this is done by making a portion of the inner conductor movable and attaching it to a screw which can be turned by a tuning knob. The coupling loops don't affect the resonant frequency but they do help determine the selectivity of the cavity.

### Selectivity

Selectivity is the ability of a cavity to select one frequency and reject the rest. The ideal selective cavity would have a response curve like that shown in Figure 3-2. (The frequencies are shown along the horizontal axis of the chart and attenuation values are shown along the vertical axis.)

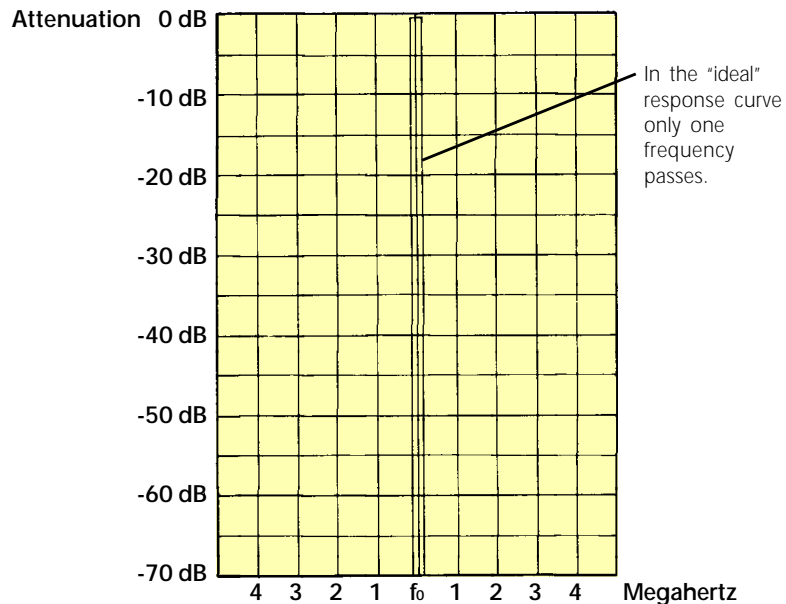

Figure 3-2: Narrow Band of Frequencies

### 3-4 About RF COMMUNICATIONS

---

According to Figure 3-2, a very narrow band of frequencies passes through the cavity with very little attenuation. Since we need a little more room for the modulation, we allow a narrow band of frequencies to pass through instead of limiting it to a single frequency. This narrow band of frequencies (centered on  $f_0$  in Figure 3-2), represents the frequency to which the cavity is tuned; this is referred to as the cavity's resonant frequency. All other frequencies outside this narrow band don't get through at all — just what we need for real selectivity. Unfortunately, no one has ever been able to build the “perfect” cavity — that is, one that can be tuned to pass an extremely narrow band — but, excellent results can be obtained with the technology that is available.

Figure 3-3 shows the response curve for a typical cavity. The chart is arranged as before: the frequencies are shown along the horizontal axis (with the resonant frequency represented as  $f_0$  in the middle) and the attenuation values are shown along the vertical axis.

For the frequency to which the cavity is tuned ( $f_0$ ), and for a little bit above and below this frequency, there is very little

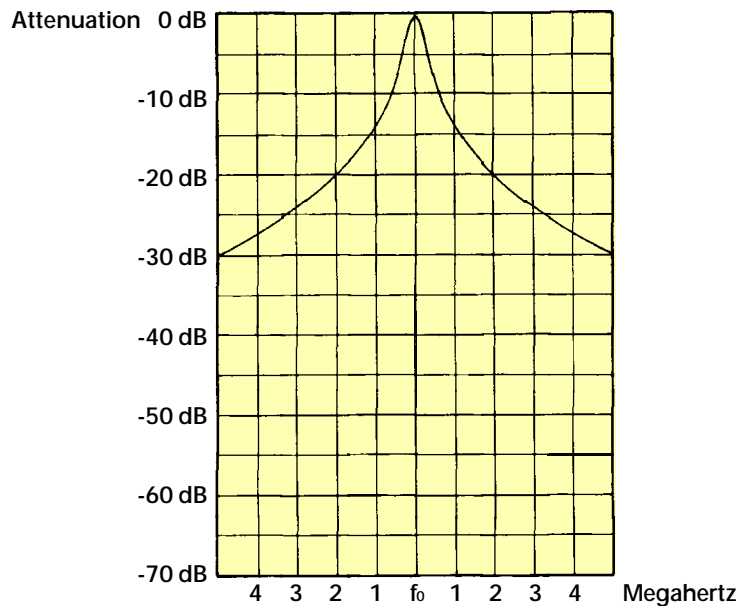

Figure 3-3: Response Curve for a Typical Cavity

attenuation, only about a half of a dB. (A half of a dB is a power reduction, or attenuation, of about 11 percent.)

For frequencies outside of the narrow band, however, things get more difficult. For frequencies 0.6 megahertz (600 kilohertz) above or below  $f_0$  the attenuation is 10 dB. (An attenuation of 10 dB is a reduction of 10 to 1.) For frequencies 2 megahertz from  $f_0$ , the attenuation is 20 dB, a reduction of 100 to 1. And at 5 MHz from  $f_0$ , the attenuation is 30 dB, or a reduction of 1000 to 1. To put it another way, a signal that is 5 MHz away from  $f_0$  will only be 1/1000 as strong when it leaves the cavity as it was when it entered.

The attenuation of half a dB at the center frequency indicates what is referred to as a tightly coupled cavity. Conversely, Figure 3-4 shows the response curve of a loosely coupled cavity. Here the  $f_0$  attenuation is 3 dB (a 2 to 1 reduction). But notice how much steeper the sides of the response curve are and how much lower they go before they start to flare out. At only 0.4 MHz (400 KHz) away from  $f_0$  the attenuation is 20 dB. At 1 MHz away it's 30 dB and at 5 MHz away the attenuation is 50 dB — a reduction of 100,000 to 1.

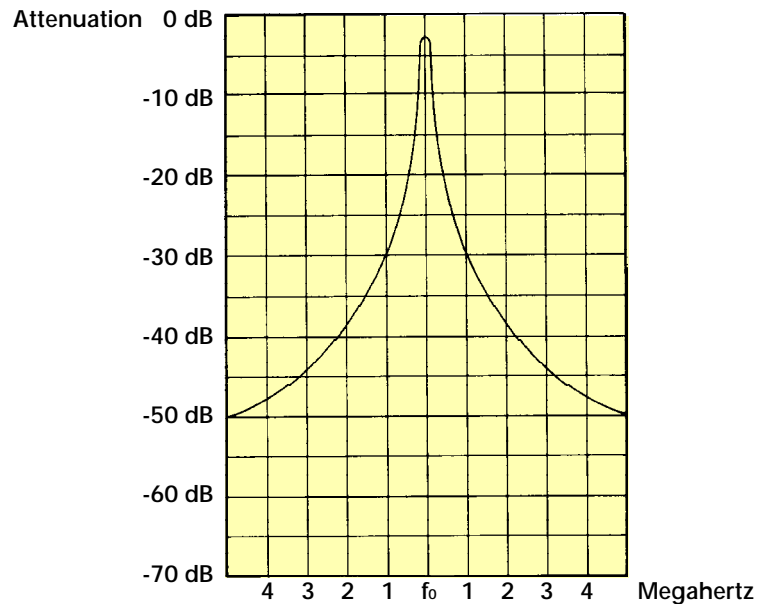

Figure 3-4: Response Curve of a Loosely Coupled Cavity



### Insertion Loss

If we compare Figures 3-3 and 3-4, we can say that loosening the coupling increases the selectivity — but with increased attenuation of the desired frequency. This attenuation at  $f_0$ , the desired frequency, is referred to as insertion loss. Our objective when using a cavity is to obtain the optimum combination of selectivity and insertion loss — that is, having only enough selectivity to solve the interference problems while keeping insertion loss at a minimum.

### How to Obtain Selectivity

The coupling loops, or the degree of coupling, are not all that govern the selectivity of a cavity or that make one cavity design better than another. The other major factors are: the volume of the cavity, the internal RF losses, and the frequency of operation.

The volume of the cavity depends, of course, on its length and diameter. For proper operation, a cavity must be a minimum of  $1/4$  wavelength long, electrically. This works out to be about seven inches long at 450 MHz, about 20 inches at 150 MHz, and about six feet at 30 MHz. There are ways to make cavities shorter, however, by using end-loading or helical center conductors. Also, if preferred, a cavity can be  $3/4$  wavelength long, electrically. This becomes practical for making a 450 MHz cavity the same length as a 150 MHz cavity.

Since the length is fixed we can increase the volume of the cavity only by increasing its diameter. But, beyond a diameter of about  $1/4$  to  $1/3$  the length of the cavity, we gain very little increase in performance. In addition, as the size of the cavity increases, so does the cost and the inconvenience of handling. As a result, the diameter of most cavities is typically  $1/4$  to  $1/3$  their length.

### Internal Losses

The internal losses are determined by the kinds of materials used in the cavity, with materials having the lowest resistance at the radio frequencies being preferred. The most desirable materials are silver, copper and aluminum, in that order. At frequencies below 500 MHz, there is little electrical difference in the three materials; however, it may make a significant

difference at frequencies above 500 MHz. The most important requirement if we use copper or aluminum is to keep them from corroding. This can be accomplished by silver plating and/or lacquer-coating them.

### Determine the “Q” of the Cavity

The volume of the cavity and the internal losses determine the “Q” of the cavity. The greater the volume and/or the lower the internal losses, the higher the “Q” of the cavity. A high “Q” is preferred over a low “Q” because the higher the “Q” the more selective the cavity. (There are actually two “Q” figures: Unloaded “Q” and Loaded “Q”. These are not important for our discussion here; however, they may be important when comparing cavity specifications.)

There’s not much we can do about the cavity’s frequency of operation since that depends upon the system in which the cavity will be operating. Unfortunately, the higher the frequency the more difficult it is to obtain selectivity. This is due to a rule that says: bandwidth, or selectivity, is directly proportional to frequency and inversely proportional to the “Q” of the cavity. Algebraically stated this would be:  $\text{Bandwidth} = \text{Frequency} \div \text{“Q”}$ .

We can go up in frequency rather easily, but we can’t increase the “Q” as quickly. So, it’s more difficult to be selective at high frequencies than at low frequencies.

### Obtaining Greater Selectivity

Let’s consider what can be done when a cavity won’t provide enough selectivity without excessive insertion loss. For example, to solve an interference problem caused by a signal that is 2 MHz off from our receiver frequency, it must be reduced by 32 dB before it reaches our receiver. Figure 3-5 shows us that one cavity with 1/2 dB loops (or a 1/2 dB insertion loss) will provide only 16 dB of attenuation to the interfering signal. And, at 1/2 dB, we’re losing about 11 percent of our signal power inside the cavity.

Figure 3-6 shows that the same cavity with 3 dB loops (or a 3 dB insertion loss) will attenuate the interfering signal by 36 dB. This gives us the attenuation we want, but a 3 dB insertion loss means we’re losing about 50 percent of our signal



power inside the cavity.

There is another way to obtain the attenuation we want without losing half of our signal power. If we put two cavities in series, each with 1/2 dB loops, the unwanted signal will be attenuated by 16 dB in each cavity for a total of 32 dB. But, because the desired signal is attenuated by only 1 dB (1/2 dB in each cavity), we only give up 20 percent of our signal power. Obviously, that's much better than the 50 percent loss we see if we use the 3 dB loops.

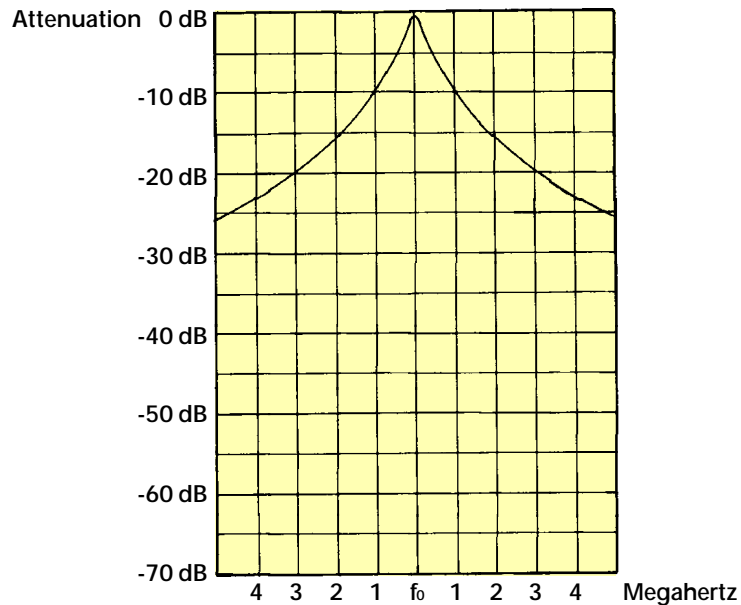

Figure 3-5: Cavity with 1/2 dB Loops

Simply stated, as we can see from this example, it is far better to obtain the desired attenuation using several tightly coupled cavities instead of one loosely coupled cavity. There is a limit to this procedure, however. Because of other factors, it's usually not practical to use more than three cavities in series and, it's almost never practical to use more than four cavities in series.

### Dissipating Power in the Cavities

As mentioned earlier, we can use cavities to add selectivity ahead of the receiver. Also, since a transmitter doesn't emit on

a single frequency (there are typically low-power noise sidebands) we can use cavities to sharpen the output of a transmitter.

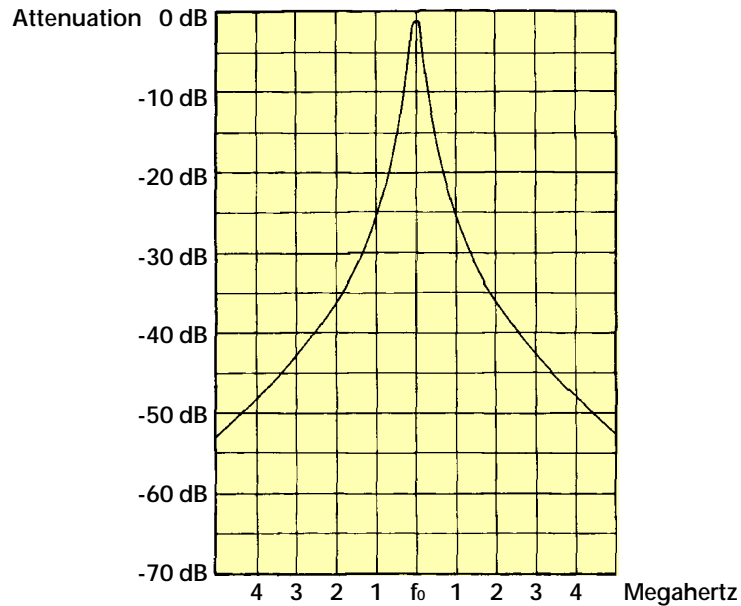

Figure 3-6: Cavity with 3 dB Loops

When the cavity is in series with the transmitter we need to be concerned with the amount of power the cavity can handle. With 1/2 dB loops in the cavity, about 11 percent of the power will be “lost” in the cavity and this lost power must be dissipated by the cavity. For example, with a 100-watt transmitter the cavity will have to dissipate 11 watts, or with a 250-watt transmitter it will have to dissipate 28 watts.

Dissipating this power doesn't present much of a problem to a typical cavity with its large metal conducting surface, but if we consider a 3 dB loop cavity being used with a 350-watt transmitter, a 3 dB insertion loss means that 50 percent of the transmitter power, or 175 watts, must be dissipated by the cavity. This is more than most cavities — even with their large metal conducting surface — can handle.

Thus, power handling limitations of the cavities must be observed. This represents another good reason for using a series of cavities — each with a low insertion loss — and letting each cavity dissipate a portion of the lost power.

### More About Coupling Loops

So far, we have discussed using cavities with various insertion losses. We have also stated that insertion losses, or coupling loop losses, and selectivity vary with the degree of coupling. Loose or tight coupling can be obtained in several different ways.

Some cavities have permanent coupling loops. In these cavities, the only way we can get different selectivity characteristics and different insertion losses would be to change out the cavities. On the other hand, some cavity designs have replaceable coupling loops. In these designs, if we wanted to change from 1 dB loops to 3 dB loops, for example, we would simply remove a few screws, take out the old loops, put in the new ones, and replace the screws. Ordinarily, these replaceable loops come in several "sizes" — 1/2 dB, 1 dB, 2 dB, or 3 dB. Since it's usually difficult to figure out in advance precisely how much selectivity will be required, it's often handy to have different sizes of loops available when trying to solve a particular interference problem. The overall goal, of course, should be to use the lowest insertion loss possible and still solve the problem by rejecting the interfering signal.

The next alternative is to use cavities with variable coupling loops. In this type of cavity, the loops are not changed. Instead, they are moved closer to or further away from the center conductor. This movement is usually accomplished by rotating the loops. For tighter coupling they are moved closer to the center conductor; for looser coupling they are moved away from the center conductor. With this method it is possible to obtain the lowest insertion loss and still obtain the required selectivity to solve the problem. This also eliminates the need to use different sized loops.

We should mention that the coupling loops must be of the right size and shape to match the impedance of the connecting coaxial cables. The cavity manufacturer takes care of this detail, however.

### Stability

To be truly helpful, the cavity must have frequency stability. If a cavity shifts resonant frequency and requires retuning with changes in temperature or with mechanical shock, it's

going to be more of a hindrance than a help. When tuned to a particular frequency, the cavity must stay tuned to that frequency.

Mechanical stability merely requires an application of sound mechanical engineering principles with regard to sizes, shapes, and materials. Stability in spite of temperature change requires that the length of the inner conductor remain constant, or very nearly so, when the temperature varies. Expansion or contraction of the outer conductor isn't of great concern since only that part of the outer conductor equal in length to the inner conductor is in the resonant circuit. The "excess" part of the outer conductor is actually not being used electrically. And, if the diameter of the cavity changes because of expansion or contraction, it only changes the volume of the cavity — and only slightly at that — so just the "Q" of the cavity changes, not the resonant frequency.

To keep the length of the inner conductor constant, a metal is needed that doesn't expand or contract with variations in temperature since the movable part of the center conductor is attached to the tuning screw. This problem can be easily solved if the metal used for the tuning screw is one that isn't affected by temperature changes.

Fortunately, a nickel-steel alloy known as invar, which has a low temperature coefficient of linear expansion, can be used. This means that if a cavity's inner conductor is made of invar, there will be little expansion of the alloy with changes in temperature. (To be more precise, a 2-foot length of invar will only change by 0.00145 inches in length with a temperature change of 100 degrees Fahrenheit.)

### **Cavity Installation**

Typically, the installation of a cavity is quite easy since the cavity can be mounted in any position. The biggest consideration is to leave room to access the tuning knob.

The cavity is placed in the circuit by means of coaxial cable and the appropriate connectors. And, since there's no difference in the coupling loops, either one can be used for input with the other being used for output.



## **Tuning**

If the cavity is to be used with a transmitter, a wattmeter should be used on the output side of the cavity; the cavity should then be tuned for a maximum power reading.

In tuning the cavity, when it is used in series with a transmitter, it's necessary that a load of some kind — either an antenna or a dummy load — be connected to the output. Otherwise, the cavity will have to dissipate all of the transmitter power which will probably result in damage to the cavity. The transmitter, of course, should be set to the "tune" power position for the initial cavity adjustments.

If the cavity is being used in series with a receiver, the easiest way to tune it is to have a low level, on-frequency signal from the antenna. Then adjust both the cavity and the receiver antenna coil for maximum limiter current. You could start with a signal generator but be sure to "touch up" the cavity and receiver antenna coil after the antenna has been connected.

A selective cavity is both highly useful and easy-to-use and it's the solution to many troublesome interference problems.



# Duplexers

Consider for a moment how difficult an ordinary conversation would be if our telephone systems were “simplex” systems. With a simplex system, you talk to the other party, then listen, then talk again; but you can’t talk and listen at the same time. So, if you miss the first part of the other person’s message, you must wait until he finishes talking before you can ask him to repeat it. This “built-in delay” slows the thought process and makes an exchange of information more difficult.

Fortunately, we aren’t confronted with this problem because our telephone systems are “duplex” systems. This means we can carry on a normal conversation with each party easily talking back and forth.

But what about our radio systems? If a duplex system is superior to a simplex system, why are most of our radio systems simplex? There are several reasons, the most common of which are:

- (1) A duplex system requires the use of two frequencies (one for transmit, one for receive) and only certain radio users can obtain authorization for use of a second frequency.
- (2) A duplex system requires additional equipment so the system is typically more costly than a simplex system.
- (3) With a duplex system, certain unique technical problems must be overcome. And, that’s where our discussion about duplexers begins.





### The Simplex System

The typical simplex system consists of a transmitter and receiver operating on the same frequency (see Figure 4-1). Since you can't transmit and receive at the same time, the antenna change-over relay (located within the radio set) switches the antenna to the transmitter whenever the microphone button is depressed; then, it switches to the receiver whenever the microphone button is released.

If the transmitter and receiver shown in Figure 4-1 were both connected directly to the antenna system, bypassing the antenna change-over relay, the receiver would be severely desensitized and its performance degraded. In addition, it would probably be physically damaged by the output power of the transmitter. And, not only would the receiver suffer, the transmitter would be less efficient since a portion of its power would go directly into the receiver.

### The Duplex System

There are numerous types of duplex systems, but they all have one thing in common: the transmitter operates on one frequency and the receiver operates on another. The duplex system generally is installed to accomplish one or more of the following goals:

- (1) to replace the wire-line control circuit between the base station and the remote control point, and/or
- (2) to extend or relocate the coverage area of a radio system, and/or
- (3) to improve the exchange of information between two parties by allowing the parties to transmit and receive at the same time.

The Mobile Repeater System is probably the best example (and least complicated) of all duplex systems. It involves little more than the equipment used with the conventional simplex system yet it provides considerably greater range between one mobile unit and another.

Consider first the typical simplex system (see Figure 4-2).

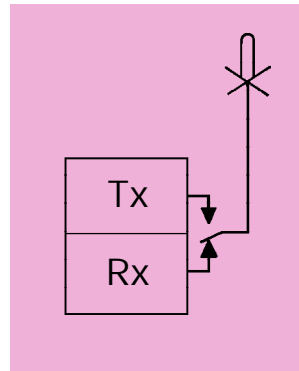

Figure 4-1: Simplex System

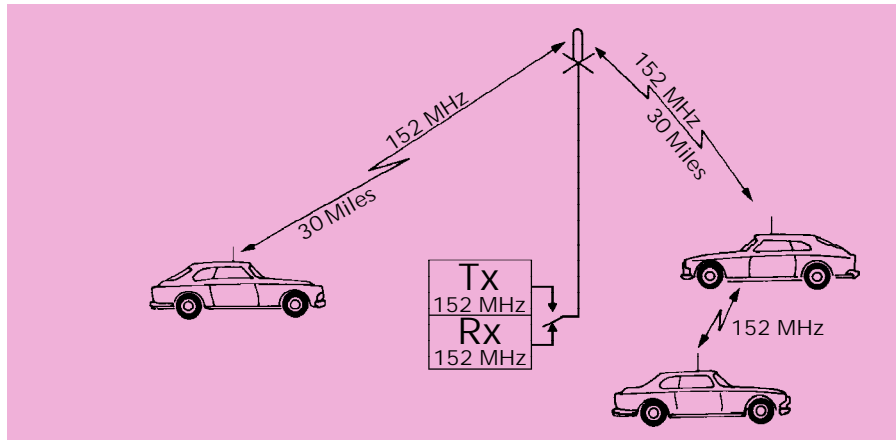

Figure 4-2: Mobile Simplex System

This system might be expected to provide communications over a distance of 30 miles between the base station and mobile units, and possibly 10 miles between the individual mobile units.

Now, consider the same system installed as a mobile repeater system (see Figure 4-3). This system provides the same 30-mile coverage between the base station and mobile units as before, but, since the repeater will retransmit any signal it receives, coverage between the individual mobile units can increase up to a distance of 60 miles.

For example: As the first car transmits its audio signal, the

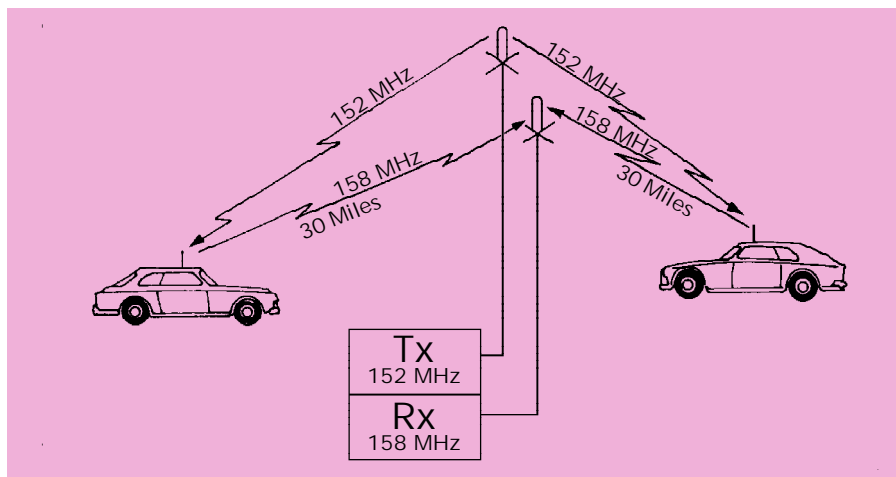

Figure 4-3: Mobile Repeater System #1

## 4-4 About RF COMMUNICATIONS

signal — or radio frequency — strikes the base station's receiving antenna. The signal travels down the transmission line to the receiver where it is routed into a coupling device. The coupling device causes the transmitter to turn on, and, at the same time, the radio signal is fed into the transmitter where it is rebroadcast on a different frequency through the transmitter antenna. Since all of this occurs virtually at the speed of light, the reception of the final signal is almost simultaneous with the transmission of the original signal.

From an operational standpoint, the use of the mobile repeater system could eliminate the need for an operator at the base station or office. Even so, however, most systems include an operator or control point so communications are available between the office and the mobile units.

There are many types of duplex systems. Two more examples are shown in Figures 4-4 and 4-5.

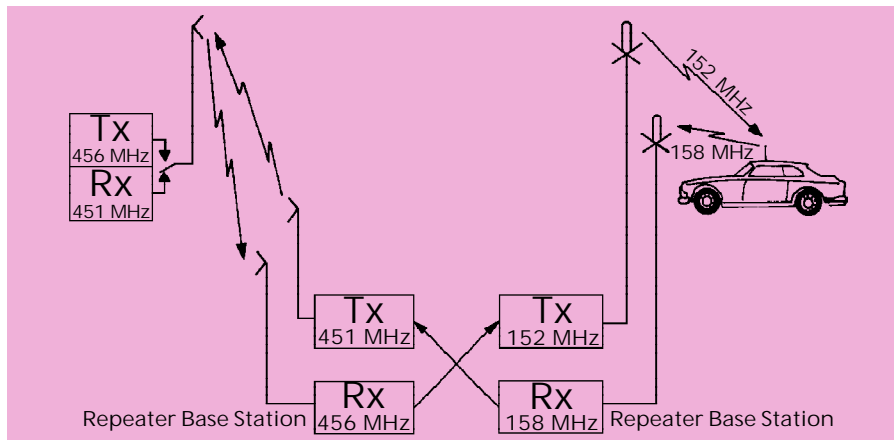

Figure 4-4: Mobile Repeater System #2

### Why No Duplexer?

In each of the preceding illustrations, we have not shown the use of a duplexer. The reasons are twofold:

- (1) the theory of operation of a duplex system is easier to understand without the duplexer and,
- (2) it demonstrates that a duplex system does not necessarily have to include the use of a duplexer. Two separate antennas — one for transmit and one for receive — can serve the function of a single antenna and duplexer, or vice versa.

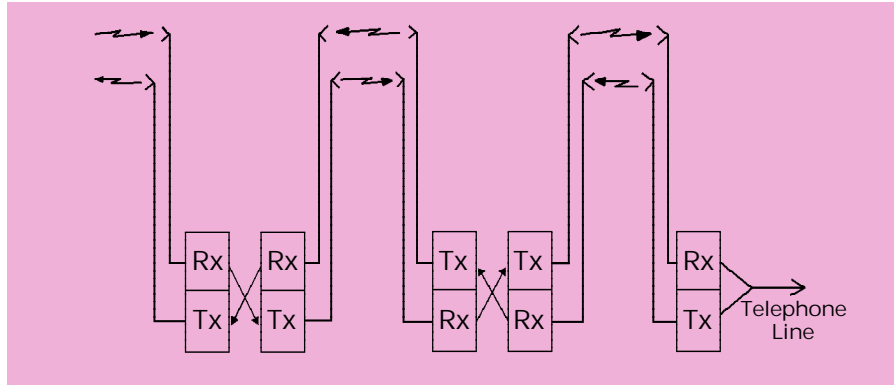

Figure 4-5: Mobile Repeater System #3

### The Need for Isolation

The reason two antennas — or a single antenna and a duplexer — are used in a duplex system is to obtain “isolation” between the transmitter and receiver. Since adequate isolation must be provided in every duplex system, this isolation, expressed in dB, is one of the most important considerations in the design of any duplex system. If adequate isolation is not provided, performance of the receiver will be adversely affected by its associated transmitter. Let’s examine why a transmitter on one frequency can degrade the performance of a receiver operating on a different frequency.

The specifications covering a typical receiver, for example, might show that any RF signal outside the receiver’s extremely narrow passband of 50 KHz or less will be attenuated by up to 100 dB — a power reduction of 10,000,000,000 to 1. If the receiver is that selective, why be concerned about a transmitter operating on a frequency that is, say, 5 MHz away? A considerable portion of our discussion of duplexers will focus on the answers to this question. We’ll start by taking a closer look at the characteristics of our transmitter and receiver.

### Receiver Selectivity

The modern communications receiver receives a relatively high frequency signal (50 MHz, 150 MHz, 450 MHz, etc.) and systematically lowers the frequency, in steps, as the signal passes through various stages of the receiver. As the frequency of the signal becomes lower, the passband of the receiver can



be made more narrow and more selective (see Figure 4-6). Finally, the received signal is lowered to a point where the circuitry in the receiver is able to pass an extremely narrow band of desired frequencies while rejecting all other frequencies by, let's say, 100 dB. This is considered the overall selectivity of the receiver and, appropriately, is the performance characteristic described on the receiver specification sheet.

Remember, though, it took virtually all of the receiver's stages to finally narrow the passband to a narrow band of frequencies. The receiver's selectivity wasn't, and can't be, this sharp at its input. While the overall selectivity of the receiver is excellent, the front-end stages of the receiver are relatively broad. As a result, it cannot completely reject the strong signal from our transmitter even though the transmit frequency might be several megahertz away from the receive frequency.

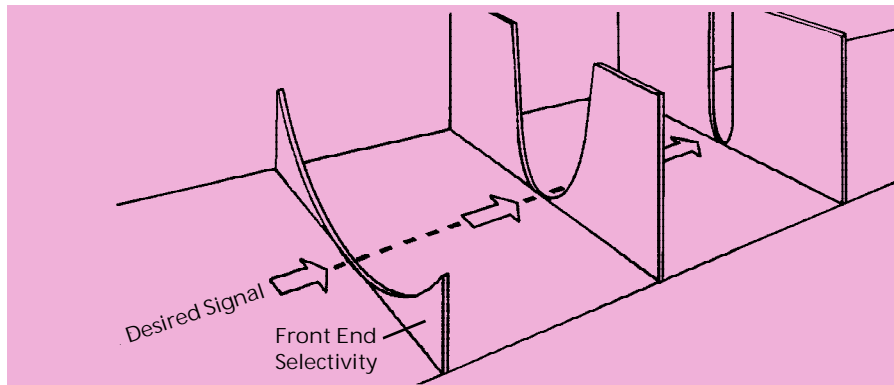

Figure 4-6: Selectivity

### Receiver Desensitization

For optimum performance, critical voltage and current levels exist at certain points throughout the front-end stages of a receiver. If these levels are radically changed, the performance of the receiver will become erratic and/or degraded at its operating frequency.

This being so, whenever the signal from a nearby transmitter enters the front-end stage of the receiver, the receiver's performance is degraded. In fact, this problem is so common it has a name: receiver desensitization.

Receiver desensitization results from a strong, off-frequency carrier from a transmitter that is close in both frequency and in

location; and, it doesn't have to be as close in frequency and location as you might think. A transmitter can be operating several megahertz from our receiving frequency and/or be located several thousand feet from our receiving antenna and still cause receiver interference (see Figure 4-7).

With a duplex system, we know our transmitting frequency will be fairly close to our receive frequency. We also know the transmitting antenna will usually be close to — and possibly the same as — our receiving antenna. This fact alone makes it obvious that we need to isolate the receiver from the degrading effects of other transmitters in the area; however, let's consider another problem that exists whenever a transmitter is operated in close proximity to a receiver.

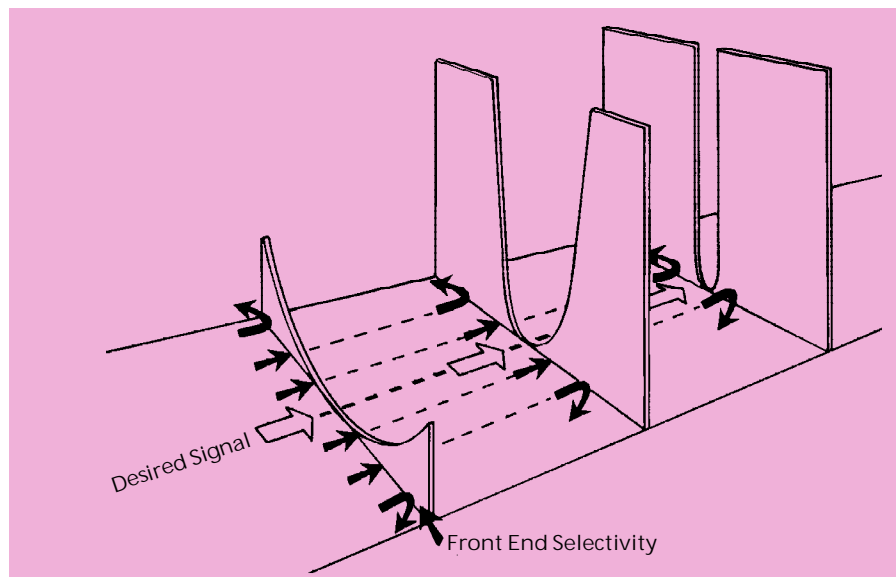

Figure 4-7: Selectivity

### Transmitter Noise

Ideally, we would have our transmitter confine all of its output power within a narrow band of frequencies on the assigned transmit channel. Unfortunately, this isn't possible. Certainly, the bulk of the power is confined within the assigned channel but some of the power is radiated on other frequencies above and below the carrier frequency. This undesired radiation is referred to as "transmitter broadband noise radiation" or simply, "transmitter noise."

Filter circuits in the transmitter eliminate a considerable portion of this undesired radiation but, even so, enough noise energy is radiated to degrade the performance of a receiver operating several megahertz away. The level of noise is greatest at frequencies close to the transmitter's carrier frequency (see Figure 4-8).

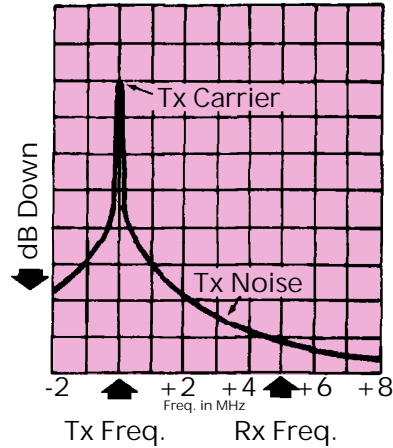

Figure 4-8: Transmitter Noise

Transmitter noise appears as "on-channel" noise interference to the receiver and cannot be filtered out at the receiver. It falls exactly on the receiver's operating frequency and competes with the receiver's desired signal. But don't confuse transmitter noise interference with receiver desensitization discussed earlier; these are two entirely different forms of interference.

Transmitter noise appears as on-channel interference to the receiver. It masks the receiver's desired signal and reduces its effective sensitivity. Receiver desensitization is the result of a strong off-channel transmitter carrier entering the broad front-end of the receiver. It upsets critical voltage and current levels and reduces gain of the receiver. Both forms of interference degrade the performance of the receiver, but they are different and must be eliminated by different means. Now, let's look at isolation between the transmitter and the receiver.

### Isolation Between Transmitter and Receiver

We have established that in a duplex system a certain amount of isolation must exist between the transmitter and the receiver if normal receiver performance is to be expected.

The questions that now arise are:

- (1) how much isolation is required to protect the receiver from being desensitized by the transmitter's carrier, and;
- (2) how much isolation at the receive frequency is required to reduce the transmitter noise to a level that will have little or no effect on the receiver's performance?

The answer to both questions depends upon a number of things: It depends upon how close together the transmitter and receiver frequencies are; it depends upon the frequency band; it depends upon the output power of the transmitter; and, it depends upon the individual characteristics of the transmitter and the receiver — and each of these characteristics will vary with manufacturer and model. Unfortunately, therefore, specific answers to each of these questions cannot be covered in our discussion here. For specific answers regarding specific equipment, it will be necessary to contact the manufacturer of the radio equipment. Usually, the radio equipment manufacturer will have data — such as that shown in Figure 4-9 — which covers each radio model that might be used in duplex systems.

At a given separation between transmit and receive frequencies, the curves shown in Figure 4-9 will indicate the amount of isolation (in dB) that must be provided to protect the receiver from its associated transmitter. One curve illustrates the amount of isolation required to protect the receiver from being desensitized by the transmitter; the other shows the amount of isolation required to reduce transmitter noise to a negligible level.

The important thing to notice is that the characteristics readily change as the frequency separation is decreased. The isolation requirement might double, for example, when the frequency separation is reduced from 5 MHz to 1 MHz.

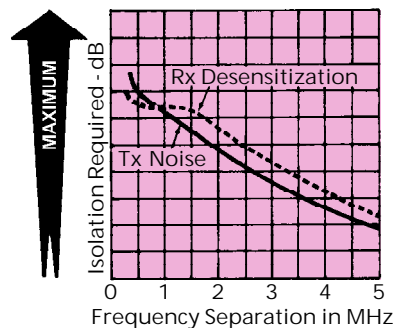

Figure 4-9: Isolation

### Obtaining Isolation

Once the amount of isolation required for a duplex system is determined, we can obtain this isolation by either:

- (1) using an appropriate duplexer or,
  - (2) using two antennas separated by a given distance.
- Let's take a look at the second option first.



### Horizontal Antenna Separation

We know the intensity of a radio signal rapidly diminishes, or attenuates, as it travels through space. Known as propagation loss, it's caused by the resistance presented by space to the radio signal.

Because of this signal attenuation, our transmitting and receiving antennas can be horizontally displaced a given distance to obtain a given amount of isolation (see Figure 4-10). If the distance between the two antennas is great enough, the receiver can be completely protected from its associated transmitter; that is, it can be protected from desensitization and from transmitter noise interference. Of course, the receiver still might be vulnerable to other transmitters located near the receiver site.

### Vertical Antenna Separation

Another means of isolating the receiver from the transmitter is by vertical separation. This is typically more effective and convenient, thus, it is used more often than horizontal separation. In this arrangement, the same tower is usually used for both antennas, with one antenna mounted a given distance above the other.

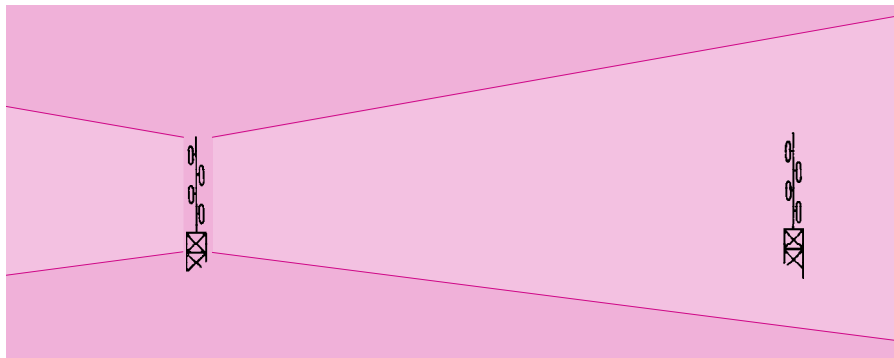

Figure 4-10: Horizontal Antenna Separation

In addition to the isolation provided by space attenuation, this arrangement allows us to take advantage of the extra isolation caused by the “cone of silence” that exists between most vertically stacked antennas (see Figure 4-11).

The cone of silence is a null — or a lack of gain — in the radiation pattern above and below the typical vertically polarized antenna.

(Graphs showing the attenuation, in dB, versus antenna separation, in feet, for half wave dipole antennas are illustrated on page 4-25. These graphs (Figures 4-26 and 4-27) cover vertical and horizontal antenna separation. A glance at these curves reveals the obvious superiority of vertical antenna separation. Please note, the isolation values obtained by vertical and horizontal separation of antennas are not directly addi-

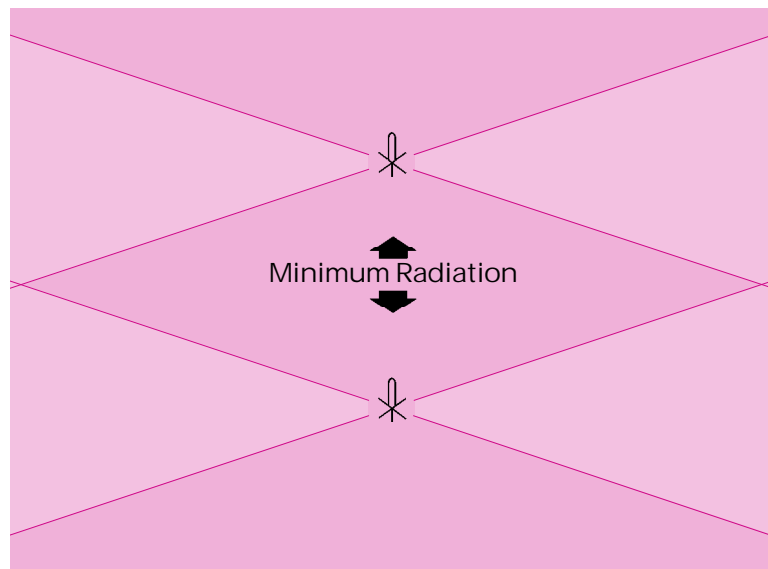

Figure 4-11: Vertical Antenna Separation

tive. If the two antennas are mounted in such a manner that both vertical and horizontal antenna separation is involved, the antenna manufacturer should be contacted for advice.)

### Using a Duplexer

In the previous paragraphs, we have discussed several physical arrangements of the antennas to achieve the required isolation between the receiver and transmitter. Another way to obtain the required isolation is to use a duplexer.

The duplexer can be used to connect the transmitter and receiver to a single antenna in such a manner that both units can be operated at the same time. This means the duplexer replaces one of the two antennas and one of the two lengths of coaxial cable in the typical duplex system (see Figures 4-12 and 4-13).



### The Advantages of a Duplexer

Generally, the savings in cost of the second antenna and cable will more than pay for the duplexer. But economy is seldom the reason for use of a duplexer. There are other, more important reasons:

(1) Isolation: The proper duplexer will provide the necessary isolation between the transmitter and receiver even when both units are connected to the same antenna.

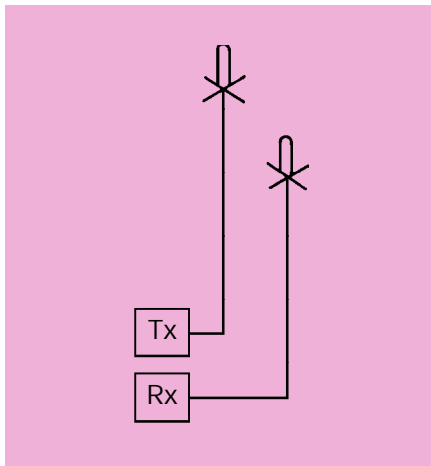

Figure 4-12: Two Antennas

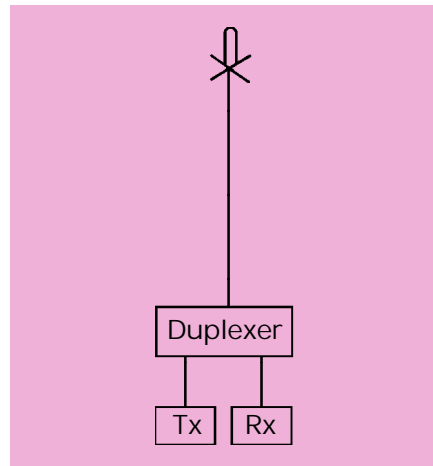

Figure 4-13: One Antenna

(2) Antenna Pattern: Without a duplexer, the duplex system must have two antennas and, since both antennas can't be physically mounted in the same location on the tower, the radiation patterns of the two antennas will typically be different. This means the coverage area of the transmitter will be different than the coverage area of the receiver. With a duplexer, the system uses a common antenna; this allows it to achieve the same pattern for both transmitter and receiver.

(3) Tower Space: Good antenna sites are scarce and usually crowded. Therefore, it will be easier to find a place to mount one antenna than it is to mount two. If space on the antenna structure — such as a tower, building, etc. — is being rented, the cost will usually be less for a single antenna.

But, as the saying goes, you can't get something for nothing. As might be expected, the duplexer will typically have some loss, or inefficiencies, that must be considered.

### Things a Duplexer Must Do

Duplexers are available in a variety of models and several of the models will appear to meet our requirements. So, which one do we choose?

In many instances, several duplexer models will meet all of our requirements, so the particular model selected becomes a matter of preference. In other instances, however, our system requirements might narrow the number of acceptable duplexer models to only a few.

Essentially, there are two distinct types of duplexers used in the two-way radio communications industry: the bandpass duplexer and the band-reject duplexer. Each type has its advantages and disadvantages, but, whatever the type, the duplexer selected must provide certain functions if optimum system performance is to be achieved. A duplexer must:

(1) be designed for operation in the frequency band in which our duplex system operates.

(2) be capable of handling the output power of the transmitter.

(3) be designed for operation at, or less than, the frequency separation between our transmit and receive frequencies.

(4) provide adequate rejection to transmitter noise occurring at our receive frequency — it's okay to have too much rejection, but not too little.

(5) provide sufficient isolation to prevent receiver desensitization. Again, too much isolation is fine, but too little results in performance degradation.

And, for greater efficiency, the duplexer should offer as little loss as possible to our desired transmit and receive signals. All other things being equal, the lower the loss, the better the system will perform.

### Losses Through the Duplexer

The output signal from the transmitter and the incoming signal to the receiver are both reduced somewhat by losses in the duplexer. These losses, expressed in dB, are usually referred to as "Insertion Loss: Transmitter to Antenna" and "Insertion Loss: Receiver to Antenna" on the duplexer specification sheets. Generally, the insertion loss will increase as the separation between transmit and receive frequencies is decreased.



For the transmitter, insertion loss values of 0.5 dB, 1.0 dB and 2.0 dB correspond to a reduction of output, in watts, of approximately 11%, 20%, and 37% respectively. For the receiver, insertion loss values of 0.5 dB, 1.0 dB and 2.0 dB mean a reduction in signal strength, in microvolts, of the incoming signal of 5%, 11%, and 20% respectively.

### **The Bandpass Cavity**

Before going into the theory of operation of the bandpass duplexer, we should first review the characteristics of the bandpass cavity. A bandpass cavity is a device that serves as a filter of radio frequencies. It has the ability to let a narrow band of frequencies pass through while frequencies outside of this narrow band are attenuated.

Energy is fed into the cavity by means of a coupling loop. This excites the resonant circuit that is formed by the inner and outer conductors. The second loop couples energy from the resonant circuit to the output. The coupling loops don't affect the resonant frequency, but they do help determine the selectivity of the cavity.

The narrow band of frequencies that pass through with only slight loss are within a few thousand cycles of the resonant frequency of the cavity. If, for example, the output of a number of signal generators or transmitters — all with the same power output but set on different frequencies — were fed into a bandpass cavity, the results would look something like that shown in Figure 4-14.

The selectivity of a bandpass cavity is usually illustrated by use of a frequency response curve. The curve indicates the amount of attenuation the cavity provides at discrete frequencies above and below the resonant frequency. It also indicates the amount of insertion loss to the desired signal — the signal being passed — at the resonant frequency of the cavity (see Figure 4-15).

If a single cavity will not provide enough rejection to an undesired signal, we can add cavities in series to improve selectivity. The additional cavity will slightly increase the insertion loss at the desired frequency but the overall selectivity is substantially improved (see Figure 4-16).



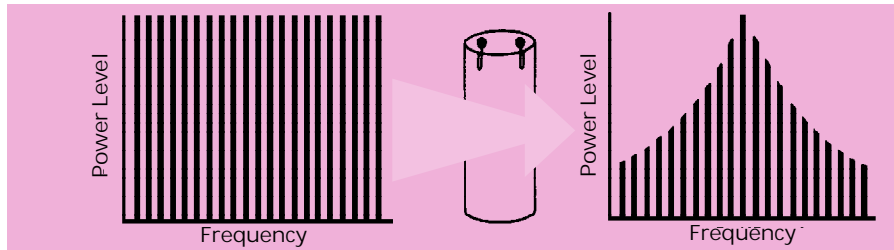

Figure 4-14: Bandpass Cavity

### The Bandpass Duplexer

The bandpass duplexer is so called because it is made up of two or more bandpass cavity filters, interconnected in a duplexer configuration.

One or more cavities are placed in the transmitter section of the duplexer and tuned to pass a narrow band of frequencies at the transmit frequency. In a like manner, the bandpass

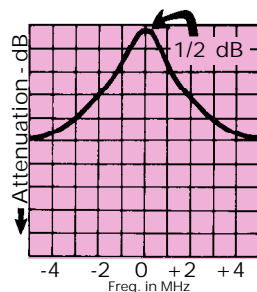

Figure 4-15: Single Cavity

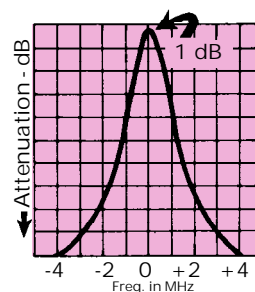

Figure 4-16: Two Cavities

cavities in the receiver section of the duplexer are tuned to pass the narrow band of frequencies at the receiving frequency (see Figure 4-17).

The output signal of the transmitter is fed through the bandpass cavities in the transmitter section of the duplexer, then to the antenna. Since the cavities are resonant to the transmit frequency, they allow the narrow band of desired frequencies (the transmitter carrier) to pass through with very little loss. But the energy on all other frequencies coming out of the transmitter is attenuated. Transmitter broadband noise that would normally be radiated from the transmitter and appear at the receive frequency is rejected and reduced to a negligible level.



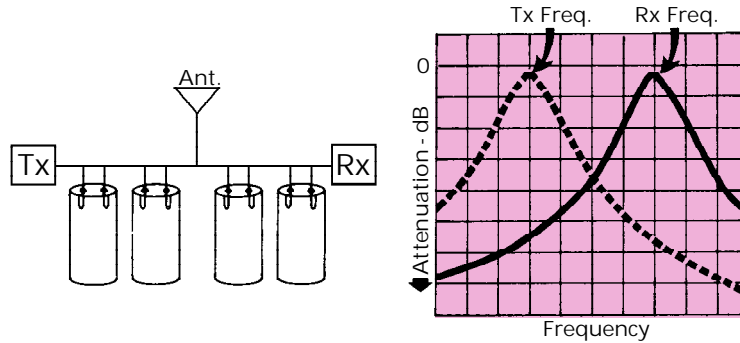

Figure 4-17: Bandpass Duplexer

By sharpening the transmitter output, the cavities not only reduce noise at our receive frequency, but — and note this bonus — they reduce transmitter noise on other frequencies as well. This means other receivers in the area might also benefit from the noise reduction feature of the bandpass duplexer. Figure 4-18 illustrates how the transmitter output signal might appear at the input and at the output of the duplexer.

The incoming signal from the antenna is fed through the bandpass cavities — usually two or more — in the receiver section of the duplexer, then on to the receiver. These cavities are resonant at the receive frequency so the desired signal passes through the cavities with only slight loss. All other frequencies on either side of the resonant frequency of the cavities are attenuated (see Figure 4-19). Essentially, the front-end circuitry of the receiver has been sharpened, or made more selective, and the receiver has been made to “see” a more narrow portion of the frequency spectrum. As a result, the

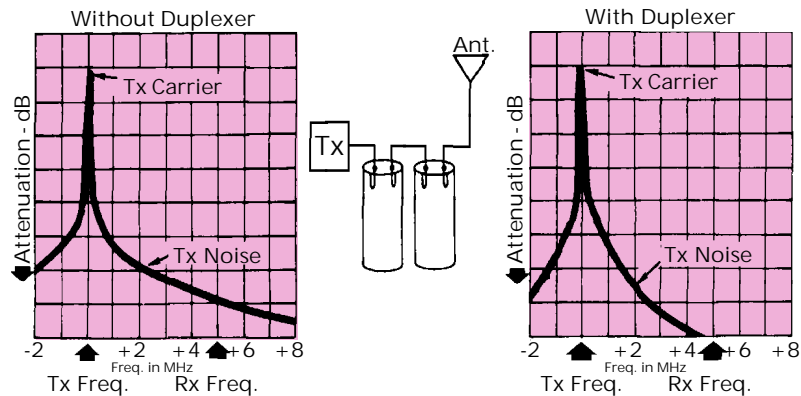

Figure 4-18: Transmitter Output

receiver is unaffected by the presence of the nearby “off-frequency” transmitter carrier. As far as the receiver is concerned, the transmitter carrier doesn’t exist. Thus, the receiver is protected from desensitization. The bandpass cavities in the receiver section of the duplexer not only protect the receiver from its associated transmitter — and again a bonus — they might also protect the receiver from being affected by other nearby transmitters.

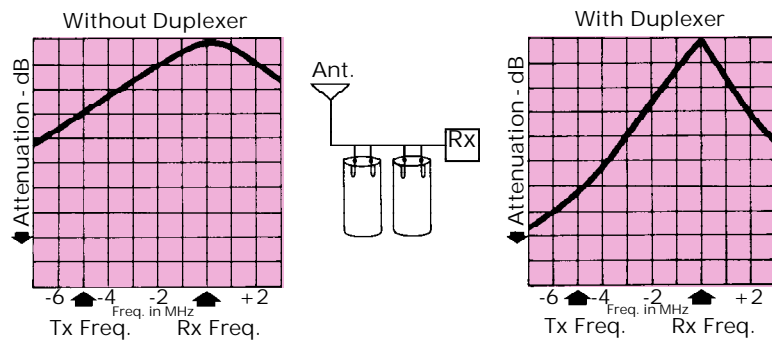

Figure 4-19: Receiver Front-end Response

### The Cable Harness

The function of the cable harness used on a bandpass duplexer warrants examination. The primary function of the cable harness is to interconnect the cavities in the duplexer. It also acts as a matching device through the use of a special length of cable in the harness. In addition, it makes the outgoing energy from the transmitter “see” the antenna as the path of least resistance; and, likewise, it makes the incoming signal from the antenna “see” the receiver as the path of least resistance.

The “matching” function is accomplished by use of special lengths of cable in the harness.

The bandpass duplexer is a relatively simple device — simple to install and simple to tune — and requires little or no maintenance. If desired, additional cavities can be added to either section to obtain additional isolation. It is not suitable, however, for use in duplex systems with “close” spacing between transmit and receive frequencies. A glance at the bandpass duplexer curve shows that, at reasonable insertion loss levels, it cannot effectively attenuate frequencies near the resonant





frequency. Maximum attenuation occurs only at frequencies far removed from the resonant frequency. Therefore, this limits the use of the bandpass duplexer to systems with “wider” frequency spacing.

### Band-Reject Filters and Band-Reject Duplexers

The Band-Reject Filter is a device that functions as a sort of “trap” for radio frequencies. The band-reject filter has the ability to attenuate a band of frequencies while allowing all other frequencies to pass through with only slight loss. Energy at the resonant frequency — the rejected frequency — “sees” the filter as a trap. As a result, the rejected frequency is coupled to, and consumed by the filter.

Maximum attenuation occurs at the resonant frequency of the filter while all other frequencies are attenuated to a lesser degree, depending upon their distance from the resonant frequency (see Figure 4-20). Unlike the bandpass cavity, the band-reject filter provides a given amount of attenuation at resonance regardless of the separation between the pass and reject frequencies. The filter can be tuned so that the narrow band of rejected frequencies can be several megahertz from the desired pass frequency, or quite close. Minimum frequency separation is limited only by the amount of loss that can be tolerated at the desired frequency.

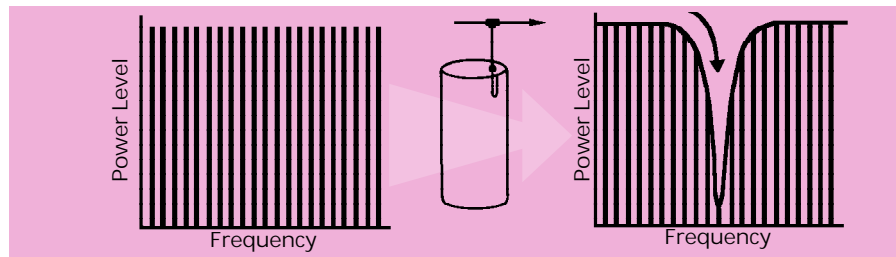

Figure 4-20: Band Reject Filter

With the use of stubs, the same filter can be made to provide one of several different frequency response curves (see Figure 4-21). Filters can be added in series to obtain additional attenuation to an undesired frequency. Essentially, two filters will provide about twice the attenuation to the undesired frequency as a single filter. The most important feature to

notice about the band-reject filter is the steepness of the frequency response curve. This unique feature permits the filter to provide maximum attenuation to an undesired frequency that is extremely close to the desired frequency.

### The Band-Reject Duplexer

As would be expected, band-reject duplexers consist of band-reject filters, or notch filters, interconnected in a duplexer configuration. One or more filters are placed in the transmitter section of the duplexer and tuned to reject a band of frequencies at the receive frequency. Conversely, the filters in the re-

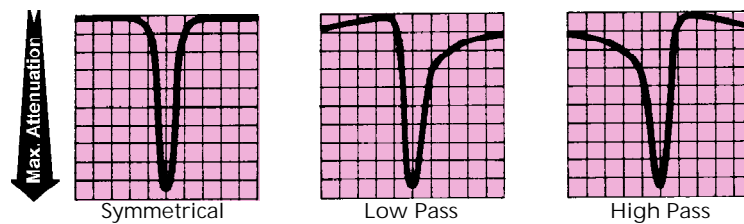

Figure 4-21: Frequency Response Curves

ceiver section of the duplexer are tuned to reject a band of frequencies at the transmit frequency (see Figure 4-22). This is exactly the opposite of what happens in the bandpass duplexer — but it works. Let's take a look at why.

The transmitter output signal is fed through the band-reject filters in the transmitter section of the duplexer, then to the antenna. Since these filters are tuned to the receive frequency, they accept and absorb the transmitter noise being radiated by the transmitter; this in noise energy that would

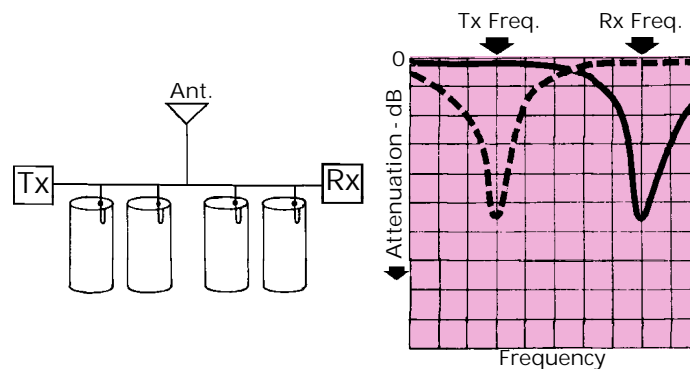

Figure 4-22: Band Reject Duplexer

normally appear at the receive frequency. The energy on all other frequencies coming out of the transmitter passes by the filters with a lesser degree of attenuation (see Figure 4-23).

The band-reject duplexer takes a more direct approach in protecting the receiver from noise being radiated by its associated transmitter. In contrast to the bandpass duplexer, the band-reject type does not alter the overall transmitter noise output.

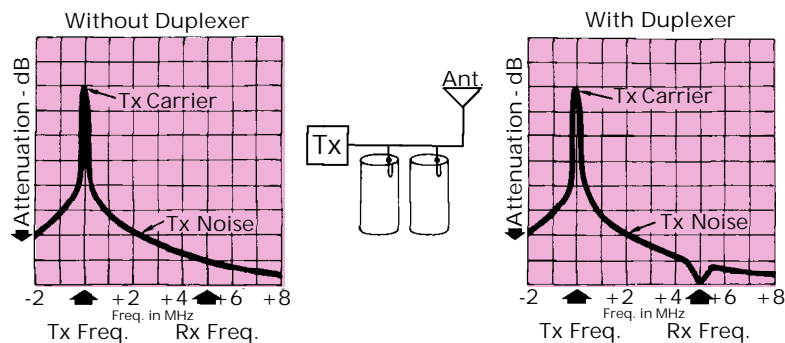

Figure 4-23: Transmitter Output

Instead, it selectively rejects transmitter noise at the critical band of frequencies at and near the receive frequency.

The incoming signal from the antenna is fed through the band-reject filters in the receiver section of the duplexer, then to the receiver. These filters are tuned to the transmit frequency so they trap out and absorb all transmitter energy at and near the transmit frequency. Again, this is noise energy that might normally enter the receiver. The desired incoming signal and energy on all other frequencies pass by the filters with only slight attenuation. The effect of the filters can be envisioned as a barrier placed in the receiver's frequency response curve; the barrier blocks the passage of any signal within a band of frequencies at the transmit frequency (see Figure 4-24).

Actually, the undesired energy is rejected and reduced to a level where it can no longer affect receiver performance. Since the receiver no longer "sees" the transmitter signal, it is protected from desensitization caused by the transmitter.

Unlike the bandpass duplexer, the band-reject type does not change the overall front-end selectivity of the receiver. Instead, it changes only a portion of the selectivity and makes

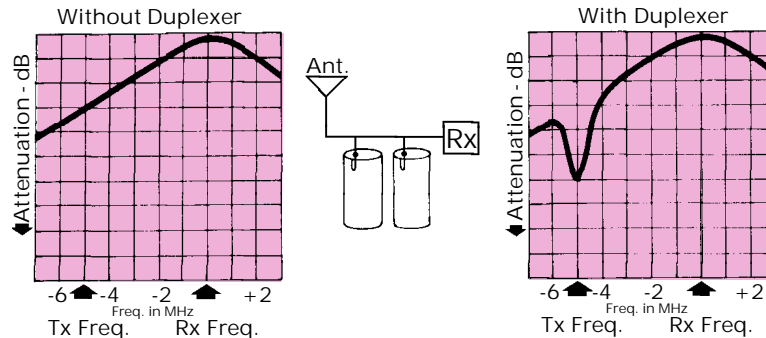

Figure 4-24: Receiver Front-end Response

the receiver unresponsive to the critical band of frequencies at and near the transmit frequency.

### The Cable Harness

The cable harness in a band-reject duplexer interconnects the filters in the two sections. In addition, the harness makes the transmitter carrier “see” the low impedance antenna in parallel with the very high impedance filters in the receiver section of the duplexer. Likewise, it makes the incoming signal from the antenna “see” the low impedance path to the receiver in parallel with the very high impedance filters in the transmitter section. That, of course, is what we want it to do.

The band-reject duplexer is probably used more often than any other type because of its compact size, low insertion loss, and excellent isolation features. It is used often at wide frequency spacing and used almost exclusively at closer frequency spacing. Many of the band-reject models include the shorter helical cavity filters which can usually be mounted inside the radio equipment cabinet.

### Other Facts About Duplexers

Other types of duplexers exist but they all operate on the principles of the bandpass duplexer, the band-reject duplexer, or a combination of the two.

Some special purpose types use coils and capacitors in an electronic circuit. These are quite small and generally limited for use in mobile units. Others include a unique cable harness (a ring hybrid) with a band-reject duplexer. These are used to



obtain additional isolation and add a slight bandpass characteristic to the basic band-reject curves. To achieve a specific isolation characteristic, still others include the use of bandpass cavities in one section of the duplexer and band-reject filters in the other, or a combination of both in each section.

### Use of Duplexers As Combiners

Duplexers can also be used to couple two transmitters, two receivers, or two single-frequency simplex stations to a common antenna. This duplexer might then be called either a duplexer or combiner (see Figure 4-25).

This use of a duplexer is often overlooked. Either the bandpass or band-reject type duplexer is suitable for this purpose and the choice of duplexers should essentially be based on the same system factors considered when combining a

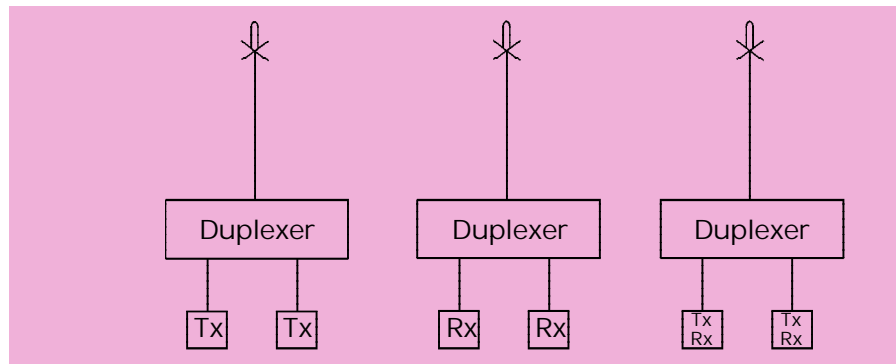

Figure 4-25: Duplexers as Combiners

transmitter and receiver. A duplexer provides a given isolation between the two units connected to its two inputs and shouldn't really care what these units might be. Of course, the duplexer is designed to handle a given amount of power so the combined output of two transmitters connected to a duplexer must be considered. The manufacturer of the duplexer should be consulted for these specifications.

### Power

A duplexer must be rated to handle a given amount of transmitter power. The power rating shown on the duplexer specification sheet probably includes some degree of safety

margin but the specified power level should not be exceeded if normal performance is to be achieved. Excess power can cause a voltage breakdown and seriously damage the unit. Excessive power may also cause excessive temperatures, detuning and/or physical damage to the duplexer.

### **Temperature**

Duplexers are expected to remain tuned and provide specified performance over an extremely wide temperature range — generally from -30 degrees C to +60 degrees C, and sometimes even greater. This presents a problem since conventional metals will contract when exposed to the lower temperatures and expand when exposed to the higher temperatures; this expansion and contraction can cause detuning.

To solve this problem, most duplexers are “temperature compensated” to ensure that the resonant frequency of the filters remains stable despite a change in temperature. Several methods of temperature compensation may be employed, but the most common is through the use of a nickel-steel alloy known as invar. This alloy has a low temperature coefficient of linear expansion. This means that when invar is used at critical points within the filters, these components will experience little expansion with changes in temperature. (To be more precise, a 2-foot length of invar will only change by 0.00145 inches in length with a temperature change of 100 degrees Fahrenheit.)

### **Frequency Separation**

Duplexers are generally rated as being suitable for use at a certain minimum frequency separation such as “3 MHz or more.” If operated at closer frequency spacing than recommended, the duplexer will probably have inadequate isolation, excessive insertion loss at the desired frequencies, or both. Duplexers necessarily must be specified as being suitable for use at a given frequency separation when used with a “typical” duplex station.

As pointed out previously, the isolation required between a transmitter and receiver at a given frequency separation will vary with manufacturer and model. If a particular duplex sta-



#### 4-24 About RF COMMUNICATIONS

---

tion is not "typical" and requires greater isolation than normally expected, the standard duplexer may have to be replaced with one offering greater isolation. If in doubt as to the amount of isolation required at a certain frequency separation, contact the manufacturer of the radio equipment. The duplexer manufacturer may be of help, but the radio manufacturer should be considered the ultimate source for this information.



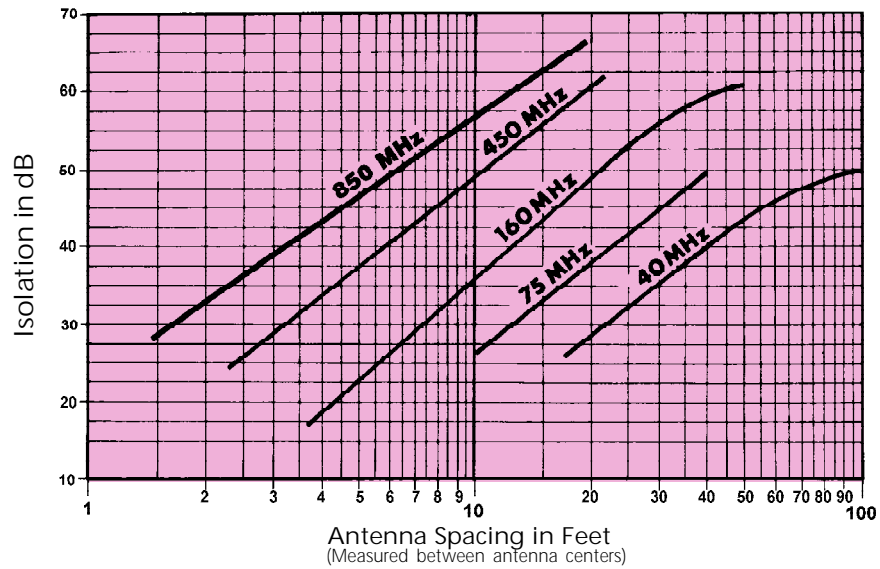

The values indicated by these curves are approximate values because of coupling which exists between the antenna and the tower transmission line. Curves are based upon the use of half-wave dipole antennas. The curves will also provide acceptable results for gain type antennas if (1) the spacing is measured between the physical ends of the antennas and if (2) one antenna is mounted directly above the other with no horizontal offset (exactly collinear). No correction factor is required for the antenna gains.

Figure 4-26: Attenuation Provided by Vertical Separation of Dipole Antennas

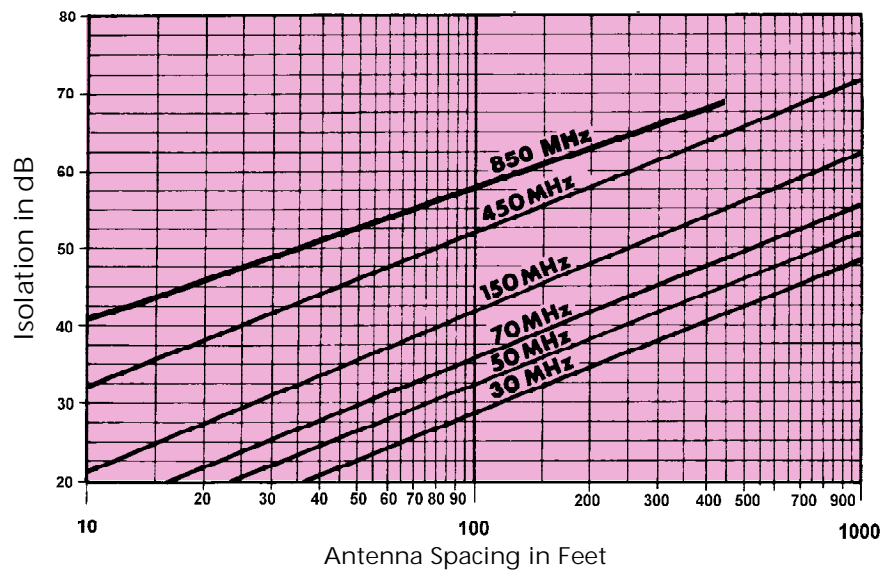

Curves are based upon the use of half-wave dipole antennas. The curves will also provide acceptable results for gain type antennas if (1) the indicated isolation is reduced by the sum of the antenna gains and if (2) the spacing between the gain antennas is at least 50 feet (approximately the far field).

Figure 4-27: Attenuation Provided by Horizontal Separation of Dipole Antennas





# RF Transmission Lines

Simply stated, the purpose of an RF (Radio Frequency) transmission line is to carry RF power from one RF device to another — for example, transferring power from a transmitter to an antenna or from an antenna to a receiver. It is also desired that during this transfer of power, as little distortion as possible be introduced by the line and as little power as possible be consumed by the line.

Multiconductor transmission lines have long been used to transfer electrical energy from a source of power — such as a battery or generator — to a load or a device that consumes power — such as a light bulb, a motor, a heating element, etc. With the development of the telephone system and the transmission of many circuits (or power signals) over a single transmission line, interference from other electrical devices became a serious problem.

In the 1930s, Bell Telephone Laboratories developed a shielded transmission cable to address the problem of interference. This shielded cable, or coaxial cable, consisted of an inner wire surrounded by a nonconductive material, called a dielectric. The dielectric is then surrounded by an outer conductor or sleeve. The entire thing is then wrapped in an outer insulating cover.

A coaxial transmission line or cable is used at radio frequencies where the energy penetrates only the surface of the conductor. This phenomenon is called skin effect and permits the outer surface of the outer conductor to be grounded. All



the current is carried on the outer surface of the inner conductor and the inner surface of the outer conductor. From this concept, the energy within the cable can only escape through terminal connections at the ends of the cable.

### **Types of Cables**

Three basic types of cables are used in two-way radio communications: solid dielectric cables, air dielectric cables, and foam dielectric cables.

**Solid dielectric** cables were developed in the 1940s and were used extensively by the military. These cables generally employ a flexible, stranded inner conductor which is surrounded by a solid extruded polyethylene insulation. This polyethylene insulator is surrounded by a braided outer conductor which is then covered by a polyethylene jacket; the jacket forms the outermost surface of the cable. These cables are easy to install and are low in cost. Disadvantages are relatively high loss, deterioration with age, and RF leakage through the braid.

**Air dielectric** cables for two-way radio service were introduced in the 1940s. Space between the conductors is mostly air (instead of an solid insulator) with small insulators, or spacers, at regular intervals to maintain proper spacing between the conductors. Advantages of air dielectric cables are low loss and long term stability. The disadvantages are the initial cost and the need to pressurize the air space between the conductors with dry air or nitrogen gas to keep moisture out of the cable. Air dielectrics are the best choice when long lengths, high frequencies, or high power is involved.

**Foam dielectric** cables were introduced in the 1950s for two-way radio installations. In this construction, the inner conductor is made of copper and the outer conductor is made of either smooth aluminum, corrugated copper, or corrugated aluminum. The space between the conductors is filled by a foam plastic dielectric. This combines the most desirable features of both the air and the solid dielectric. Pressurization is not required because the space between conductors is completely filled and the power loss falls between that of the air and the solid dielectrics. Thin wall, corrugated outer conductors provide flexibility and resistance to crushing forces and



bring the cost of the foam dielectric cables to an acceptable level.

### Mechanical Elements of a Coaxial Cable

Numerous possible materials are available for the conductors and for the dielectric. The actual choices represent compromises based upon economics and system needs. An example of a flexible, solid dielectric coaxial line is shown in Figure 5-1.

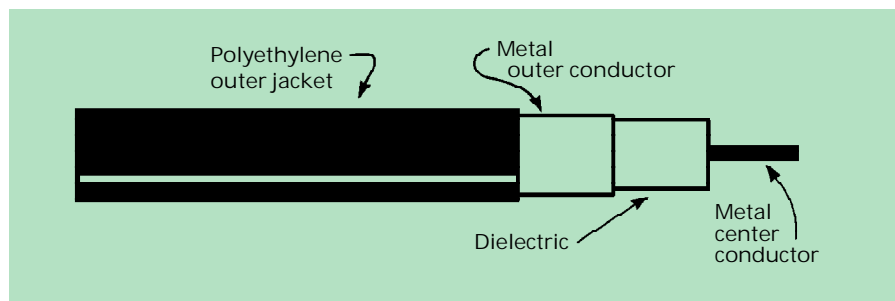

Figure 5-1: Elements of a Coaxial Cable

Since both conductors carry all of the current, and the available conducting surface on the inner conductor is small compared to that of the outer conductor, it follows that high conductivity is most important in the inner conductor. For this reason, copper is almost invariably the choice of material for the inner conductor. This may be in the form of a stranded wire for greater flexibility in the case of solid dielectric cable or copper tubing, copper clad aluminum, or silver plated steel wire.

Copper braid is used as the outer conductor on most solid dielectric cables; copper is used to achieve high conductivity and the braid is employed to increase flexibility. Aluminum or copper tubing (either smooth wall or corrugated) is used for foam or air dielectric cables. Generally, aluminum costs less per pound but has lower conductivity and less corrosion resistance and strength than copper. If employed in thin wall construction, aluminum is susceptible to highly damaging corrosion in salty atmospheres. Copper has higher conductivity and generally has greater corrosion resistance, but it costs more per pound than aluminum. Thus, copper is the usual choice

for permanent installations; however, both types are available with plastic covering.

Polyethylene dielectric is the usual choice for two-way radio cables. It is the most economical and has both low loss and long life. It can be used in either solid or foam construction or as a spiral spacer in air dielectric cables. Teflon is sometimes used as an insulation for high power service since it is capable of operating at substantially higher temperatures than polyethylene; it is typically much more expensive than polyethylene, however. Other plastics with intermediate temperature ranges and costs are also used for special purposes.

### **Electrical Properties of Coaxial Cable**

RF energy will be lost in a cable due to the attenuation of the cable. This loss is comprised of conductor loss and insulation loss. Losses are dependent upon size of the cable, conductivity of the conductors, loss factor of the insulation, and frequency.

For a cable of a given construction, attenuation is a function of size — the larger the cable, the less the attenuation or loss. This is because there is more cross-sectional area of conductor material carrying the current. Attenuation loss is usually stated in decibels per 100 feet (dB/100 feet) of cable.

Conductor loss is a direct function of the conductivity of the conductors while insulation loss is a function of the dielectric constant and the loss-power factor of the dielectric. Air offers the least insulator loss with a dielectric constant of 1.0. Polyethylene and Teflon have dielectric constants of approximately 2.0, while foam, as a mixture of air and a dielectric material, has an effective dielectric constant of approximately 1.6.

Conductor and insulation losses increase with an increase in frequency. Curves showing attenuation as a function of frequency, including the cumulative effects described above for some cables, are shown in Figure 5-4 on page 5-17.

### **Characteristic Impedance**

Characteristic impedance, usually called cable impedance, is a complex function of the ratio of the diameters of the con-



ductors. The standard impedance of cables for two-way radio service is 50 ohms which is the same impedance used for antennas, transmitters, receivers, etc. A deep dent in the cable or other defect can cause a discontinuity in impedance. The effect of a discontinuity is the same as a mismatched antenna, namely the reflection of power which can result in a high VSWR.

### **Velocity of Propagation**

Velocity of propagation in a coaxial cable is the velocity, or speed, at which the signal travels through the cable. Velocity is a function of the amount and type of dielectric used in the cable. It is expressed as a percentage of the velocity of light varying from about 67 percent for solid dielectric cables to as much as 92 percent for air dielectrics. Velocity is not usually considered a significant factor in the choice of a coaxial cable for the two-way radio base station transmission line. However, it is important because of its effect on the wavelength in the cable when resonant lengths of line are used for impedance transformers, interconnect cables for cavities and duplexers, etc.

### **Power Handling Capability**

The power handling capability of a coaxial cable is limited by the ambient temperature (the temperature of the air around the outside of the cable), the cable's temperature at average power, and by conductor spacing and dielectric strength at peak power. Peak power is rarely a factor in two-way systems, but average power frequently is a factor.

As power is lost in a cable, the temperature of the cable rises. Since power loss increases with frequency, the average power rating decreases with the increase in frequency. Therefore, since most foam polyethylene dielectrics begin to soften at about 180 degrees F (82 degrees C), a cable should be chosen which will ensure that the sum of the cable's temperature plus the ambient temperature does not exceed the cable's maximum recommended temperature. Should the combined temperatures exceed the cable's maximum rating, the center conductor could push its way through the softened dielectric and short against the outer conductor.



### **RF Leakage**

RF leakage is a function of the porosity, or the number of openings, in the cable system. In the case of braided cables, there are thousands of tiny openings. With high signal levels, significant leakage can occur. When a number of braided cables are placed close together, with all of them carrying high level signals, the interference resulting from leakage can be serious. In the case of solid sheath foam or air insulated cable, leakage occurs only at the ends or openings. Leakage problems in two-way radio installations generally occur in the connections between multicouplers, duplexers, filters, etc., when two or more braided cables are in close proximity.

### **Environmental Considerations**

Frequently, coaxial cables must be installed in hostile environments. Such conditions may include corrosive atmospheres in industrial areas and saline atmospheres in coastal areas. In addition, wind forces can induce vibration and rain or even humidity may permeate jacketing materials as the cable ages.

Temperature changes can cause a cable's conductors to expand and contract at differing rates. Also, differing expansion and contraction rates can exist between the cable and the support structure to which it is mounted. All of these factors can be destructive to coaxial cables.

### **Life Expectancy of Coaxial Cables**

The life expectancy of a coaxial cable is dependent in part upon the environment in which it is installed. However, life expectancy of the cable can be maximized through the proper choice of materials and construction. The effects of the more common destructive forces, which are discussed below, can help in making an optimum choice.

The jacketing material employed on semi-flexible and flexible coaxial lines is usually polyethylene. Polypropylene and polyvinyl chloride are also used. All of these materials deteriorate somewhat under long exposure to sunlight. Carbon black, blended into the resin prior to processing, inhibits the aging effect of sunlight. This is the reason black jacketing is generally used for outdoor cables.



Constantly exposing a cable to humidity may ultimately cause degradation in braided cables as moisture gradually permeates the plastics used in the jacketing and the dielectric. Typically, permeation of the jacket itself is relatively harmless; however, once moisture has penetrated the jacket it continues to penetrate into the dielectric causing an increase in power loss. While it's difficult to prevent moisture from penetrating a cable's outer jacket through cuts, scratches, or through cracks as the cable ages, the easiest way to keep moisture out of a cable is simply by properly sealing the end connectors. Moisture and other external impurities can enter a cable through improperly installed connectors or through connectors that are not properly connected or sealed. Small amounts of water vapor will typically condense into water and, if available in a sufficient quantity, can migrate along the braid. When this occurs, the water will attack the copper braid and potentially contaminate the entire length of cable. This is especially true if the water contains impurities which may be found in a polluted atmosphere. In addition to damaging the cable itself, moisture will usually cause a short circuit between the inner and outer conductors, especially at the connectors. Therefore, as may be suspected, a high percentage of radiation system problems are caused by moisture getting into the RF system.

### **Moisture Resistant RG Type Cable**

A significant improvement in most RG-type cables is available. This improved cable offers a unique "double defense" against the usual reasons for cable deterioration. Its outer jacket is specially formulated to resist moisture, sunlight, and corrosion and a new inert, semiliquid compound fills all space between the polyethylene dielectric and the outer jacket, flooding the copper braid. This compound adheres to the inside of the jacket, the braid, and the dielectric material. The flooding compound is not affected by normal temperature changes, condensation, or time. If the outer jacket is cut, the compound prevents moisture or gases from migrating beyond the immediate area. The viscosity of this compound permits it to actually "heal" small cuts that would typically lead to the eventual failure of most RG-type cables.





This improved cable also features a solid center conductor instead of the usual twisted wire center conductor. This design can block the travel of moisture along the center of the cable. The electrical characteristics of the cable are comparable in all respects to equivalent RG-type cable and it can be used with standard connectors.

### **Corrosion**

Corrosion is an important consideration where dissimilar metals are brought into physical contact with one another. Care must be given to the materials used in order to avoid severe galvanic corrosion. Galvanic corrosion occurs between dissimilar metals causing electrical current flow between them, similar to a battery or electroplating action.

When differing metals are brought into contact, gradual destruction occurs in the metal that is highest on the list in the Galvanic Series (see below). Of the most commonly used conductor materials, copper is the most inert while aluminum is the most active. For example, if bare copper and aluminum cables are buried close together in active soil conditions, ground current will flow between them resulting in the ultimate destruction of the aluminum cable. (Buried cables, regardless of construction, should always be jacketed.)

Galvanic corrosion can be greatly reduced by using similar metals or by plating the contacting materials or subjecting them to a chemical conversion treatment. Optimally, to reduce the effects of galvanic action, when dissimilar metals must be brought into contact, the metals should be as close to each other in the galvanic series as possible.

### **Galvanic Series**

The relative position of metals and platings commonly used to reduce galvanic corrosion are shown in the following list. A low number represents an anode and a high number represents a cathode. In galvanic action, metal flows from the lowest number to the highest number.

- 
- (1) Magnesium
  - (2) Zinc
  - (3) Aluminum

- (4) Aluminum Alloys
- (5) Cadmium
- (6) Steel or Iron
- (7) Stainless Steel (active)
- (8) Lead-Tin Solders
- (9) Lead
- (10) Tin
- (11) Nickel (active)
- (12) Brass
- (13) Copper
- (14) Monel
- (15) Silver
- (16) Gold
- (17) Platinum

## Connectors

Connectors used in the majority of two-way radio installations are usually PL259 UHF or Type-N, though other types are also available. In addition, adapters are available for both male and female Type-N to UHF.

UHF connectors are the oldest and the most popular in the industry. They are rugged, easy to install, simple to connect, mechanically reliable, and, electrically, are generally considered quite adequate up to about 300 MHz.

The Type-N connector is usually the connector of choice at 300 MHz and above. It has a constant impedance and works well electrically to about 10 GHz. There is a slight trade off, however, in that it is more fragile, more difficult to install, and more difficult to connect than the UHF-type connectors.

There are many different types of connectors available, with many designed for specialized applications. A few of the ones that are found useful in special situations are the EIA flange, DIN, HN, and BNC. Figure 5-2 shows illustrations of some typical connectors.

The EIA flange is used mostly above 450 MHz and usually on pressurized transmission lines. The HN connector is a 50 ohm, constant impedance connector. Typically, it has higher voltage characteristics than the Type-N connector.

The DIN (Deutsche Industrie Normenausschuss) is available in several sizes. The 7-16 DIN (7 mm inner conductor and



## 5-10 About RF COMMUNICATIONS

---

16 mm outer conductor) is popular for high frequency, high power, and/or low intermodulation applications.

The BNC is a small, quick disconnect connector with a bayonet-type locking coupling. Designed for small diameter cables, it is used for applications such as interconnection of equipment.

The TNC connector is threaded and is used for more positive contact in areas such as a vibration environment.

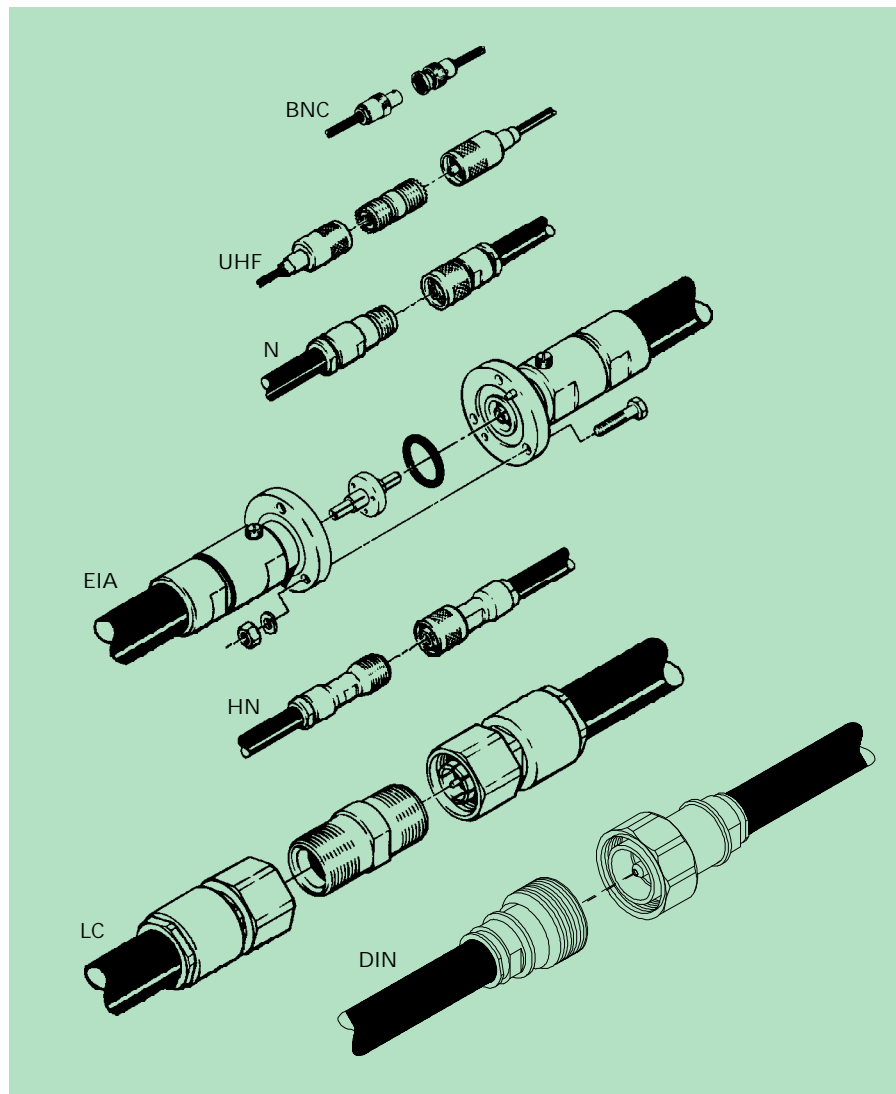

Figure 5-2: Common Cable Connectors used in RF Communications

Congested sites, especially those with RF and antenna systems in the 800, 900 and 1900 MHz frequency ranges, require that silver plated Type-N or DIN connectors be considered. This type of connector assists in the reduction of intermodulation problems.

### Installation of Coaxial Cable

A carefully planned and executed installation will assure long and trouble-free service. Before beginning an installation, it is advisable to always read the supplied instructions and to inspect the cable for shipping damage. It is especially advisable to check the pressure of air cable to ensure there are no leaks. In addition, inspect the connector on the antenna and on the antenna-end of the cable to be sure they will mate properly. A typical installation is shown in Figure 5-3.

When a cable is hoisted up a tower, a suitable line that will adequately support the weight of the cable should be used. The cable can be run up the tower by the use of a hand line or power winch. If the cable is on a reel, it should be positioned in such a way that the cable plays off the bottom of the reel toward the tower.

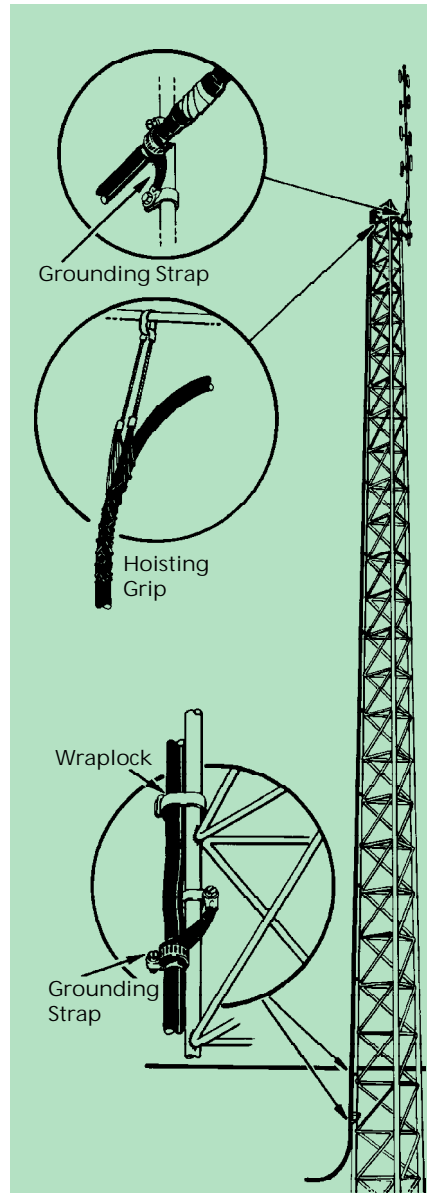

Figure 5-3: Typical Tower Installation

When the cable is shipped in rolls, the entire length should be uncoiled along the ground, away from the tower. The hoisting line should be attached to the cable by use of a cable grip or rope sling that is positioned approximately 18 inches or more below the connector. When the cable is over 200 feet long, additional hoisting grips should be used to distribute the pull in several places along the cable (150- to 200-foot intervals are recommended).

After the cable has been raised to the proper height, it should be fastened to the tower, starting at the top, near the antenna connector. The cable should be securely supported all the way down the tower using hoisting grips, band clamps, or wraplocks. Secure the cable at 3- to 5-foot intervals. All cable attachments should be secure but not so tight that they dent or deform the cable. For waveguide or larger cable (7/8" or greater) the proper waveguide or coax hanger kit should be used for support.

An all important final installation step is to waterproof all connections, especially at the antenna input. Most connectors are not waterproof, therefore, this step should not be overlooked. Weatherproofing is best accomplished by taping the entire connection with a low temperature tape and then coating it with a sealant. Special waterproofing compounds are also available from most antenna suppliers.

Grounding the cable to the tower should be done using recommended grounding kits at the top and bottom of the tower. A suitable "down" conductor that is physically separated from the cable can also be used if the tower is nonmetallic. Local building or electrical codes may also have other requirements which should be investigated and observed.

### **Selecting the Proper Coaxial Cable**

There are a number of factors involved in the selection of the optimum coaxial cable for any given installation. Factors involved are electrical, mechanical, and economic — or more specifically, frequency, loss, environment, and cost. Generally, there are usually several cables that will perform adequately for any given installation, but selection of the optimum cable for the purpose requires careful consideration of several factors.



Cost of cables is based primarily on the cable size and material content. However, additional indirect elements which need to be considered in making a selection are loss, long term stability, and installation cost. It costs money to generate RF power and each decibel lost in the cable may be hard to replace.

As we discussed earlier, loss is a function of size, frequency, length, and materials. Sometimes there is a trade-off between antenna gain and cable loss, and sometimes there is not. In some applications, a high gain antenna may be undesirable. Another factor is the dead weight and added wind load that the cable adds to the tower or antenna supporting structure.

Another factor is ease, and thus cost, of installation. Braided cables are the easiest to install while 1/2-inch is somewhat more difficult and 7/8-inch is about 50 percent more difficult.

Cables we have discussed will work over the entire two-way radio frequency spectrum but the use of a low-loss cable, particularly at higher frequencies, is generally a good economic choice.

### **The Installation Environment**

The environment in which the cable is to be installed usually determines the difficulty and cost of the installation. Also attributed to the environment — specifically sunlight and high ambient temperature — is how the power handling capabilities of a cable are reduced. This is generally not a major factor in two-way radio service, however.

### **Field Testing Coaxial Cable**

When a cable is field tested, there are three simple tests that can be performed: inner and outer conductor continuity, shorts between conductors, and VSWR.

The first two tests are self-explanatory and are performed with an ohmmeter. VSWR is an indirect measurement. The forward and reflected power is measured with a thru-line wattmeter. VSWR is then taken from a conversion table or graph supplied with the wattmeter. If all three measurements appear satisfactory but the system's performance is unsatisfactory or erratic, there may be an intermittent condition causing the



problem. This is usually the most difficult kind of fault to detect. The usual procedure is to check the connections and repeat the tests. If there is no change, try flexing the cable slightly in the vicinity of the connections, and repeat the measurements again.

### **Standing Waves or VSWR**

The VSWR, or voltage standing wave ratio, is one measure of the quality of an RF transmission line. Standing waves result from reflections. If all elements in the system are perfectly matched, the VSWR is "unity" or 1.0, also expressed as 1.0:1. If, for example, a transmitter is 50 ohms, the cable is 50 ohms, and the antenna is, let's say, 75 ohms, the mismatch at the antenna will result in a VSWR of 1.5.

However, since we are only concerned here with the cable, let's substitute a dummy load for the antenna. A wattmeter is then connected between the transmitter and the cable for a measurement of the forward and reflected power of the cable and the dummy load. After allowing for the effect of the dummy load, it can be said that the residual VSWR is due to the cable and connectors.

### **Problems and Solutions**

In the following it is assumed that the antenna and the radio equipment have been tested and found to be in good order. While we are only concerning ourselves with the transmission line itself, some of the problems and solutions could well apply to the antenna.

Reduced system coverage can occur over a long period of time or, in some cases, overnight. A talk with the user can sometimes be very informative to the technician. Finding out about a recent rainstorm, a nearby explosion, or even a potential stray bullet that resulted from the opening of hunting season could be a tip-off if the coverage has suddenly changed.

Water getting into a cable through some new opening can cause a system's range to drop greatly. Examine the connectors at both ends of the cable for signs of water. Even if it looks dry, take the connector off and a look inside; this may reveal moisture inside the connector. If signs of moisture are found, cutting off a few feet of the cable and reinstalling the



connector is in order. This may not always be a guaranteed cure, however, if water has migrated down the inside of the cable. A later change in temperature or atmospheric pressure could cause the water, and the problem, to reappear.

If the connectors look good, inspect the complete cable for holes or other signs of damage. Any sections of cable that show holes or damage must be replaced. Simply taping over the damaged areas will only trap the water inside the cable causing the trouble to remain.

If the range has decreased over a long period of time, cable aging may be the problem. Metal sheath cables usually do not age if properly installed and protected. However, inferior cables can have a short life when exposed to the sun and weather. Aging cables can cause attenuation to increase slowly, which a VSWR check may not reveal.

If intermittent problems are suspected, they should be treated the same as any other electrical circuit. Look for an open or shorted condition between the center and the outer conductors. This can occur in the cable or in the connector.

### **High VSWR**

For high VSWR, the cable should be checked with a dummy load at the antenna end of the cable. If the VSWR checks higher than when the antenna was installed (say 20% or more) there is probably an open, short, or partial short between the inner and outer conductors. An ohmmeter check is required; it should be made with the line open and then with it shorted at the top.

With the top end of the cable shorted (the cable ground should be removed) the meter should show low resistance between the inner and outer conductors. If the meter shows high resistance, then the center or outer conductor is probably broken. If the cable has a protective jacket, the break in the outer conductor may be very hard to locate and complete replacement may be more economical. Otherwise, a good visual inspection may reveal the location of the problem. If you have an unjacketed cable, the cable could still be open even when a low resistance is shown at the bottom end. The outer sheath could be broken and completely separated, but because it could be clamped tight to the tower leg, you could





be reading the return through the tower itself.

With the top end of the cable open, the meter should show very high resistance. However, one of the conductors could be open. If the meter shows low resistance, then there is probably a short between the center and outer conductors. Look for a crushed cable, a hole, or lightning damage. Don't overlook the connector and the workmanship of its installation. If Type-N connectors are pushed together at a slight angle, the male center pin can easily push the female center pin out of alignment, or even break one of the small fingers, resulting in a short.

If the meter reads a thousand ohms or less, but not zero resistance, water is most likely the problem. Water may collect in the end or inside the connector.

A real problem is water vapor. During the day when the temperature is high, the vapor may move along the cable away from the connector and be hard to find. However, at night when the temperature drops and the vapor condenses, it can show up as water in the connector again.

### **Preventive Maintenance**

Good installation procedures will minimize the need for preventive maintenance except in the most severe environments. Generally, the cable installations should be inspected whenever it is necessary to climb the tower for relighting, painting, or any other reason. Alternatively, a quarterly or semiannual inspection with a pair of high-power field glasses should suffice. Reflected power should be measured at regular intervals and recorded. The elements — sun, wind, rain, salt, temperature, etc., — are natural enemies of a cable system. A sensible maintenance program should be geared to the conditions prevalent at the site in question.



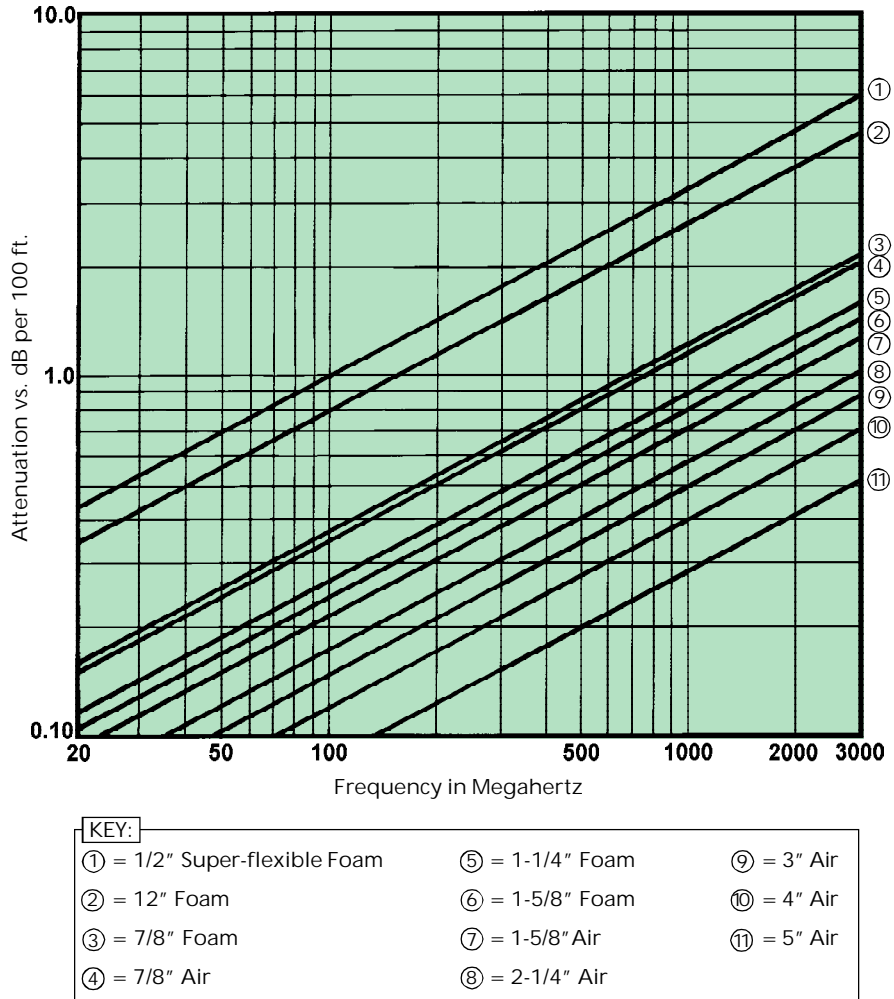

Figure 5-4: Air and Foam Cables, Attenuation vs. Frequency





# Lightning

Antennas and their supporting structures are prime targets for lightning. Because of their exposure — often times sitting alone on the top of a hill — antennas for land-based mobile and microwave radio stations are highly susceptible to the ravages of lightning.

In this section we'll take a look at ways to evaluate a radio site's lightning exposure conditions and protection levels. We'll also look at ways to protect personnel and minimize system maintenance costs and downtime caused by lightning.

In addition to providing safety for personnel, protective measures are necessary to ensure the uninterrupted operation of a two-way radio system. Major areas of an installation that demand protection are:

- Antennas and support structures
- Coaxial lines and waveguides
- Buildings and equipment housing
- Radio, multiplex, carrier, and switching equipment
- Connecting facilities such as the communication lines and power lines

## Exposure Factors

The exposure of radio installations to lightning is typically greater than that experienced by other communications facilities. Antennas mounted on tall towers not only invite lightning strikes, often times they are not properly grounded to



the tower. Since it is desirable that the majority of a strike's current be directed to ground at the tower, it's important that the entire structure be grounded. When the antenna and tower are properly and adequately grounded, the potential of damage to the station's facilities, power lines, communications lines, and radio equipment is further reduced.

Microwave horns and dishes can also be damaged by a direct lightning strike. An exceptionally heavy strike may cause damage to two-way radio antennas through fusing of dipole elements at arc contact points. Some antennas are self-protecting by design. Protection features such as star gaps and shorting stubs present a short circuit at lightning frequencies and provide some protection to both the antenna and transmission lines.

By its nature, a metal support structure can conduct surge currents to ground. On the other hand, however, a wood structure will require separate conductors between the antenna and ground. Without proper grounding a serious shock hazard exists for personnel and equipment damage can occur from the heavy charges associated with a lightning strike.

### **Evaluation of Lightning Exposure**

Many variables are present in lightning exposure situations and most are beyond our control. In protecting personnel and installations against lightning, the world of engineering has made very effective progress. No longer should lightning damage be accepted as unavoidable since the expertise and hardware exist to minimize its destructive effects. The major problem we now face is one of economics.

### **Lightning Current**

Lightning is an electrical discharge that occurs between clouds or from a cloud to the ground. The cloud-to-ground lightning is of primary concern in the protection of a radio installation.

The impedance of objects that become part of a lightning discharge path is considerably lower than the impedance of the total path. From this, we will assume that a lightning strike emanates from a constant current source. Peak magnitudes will vary greatly, however, from strike to strike depending chiefly



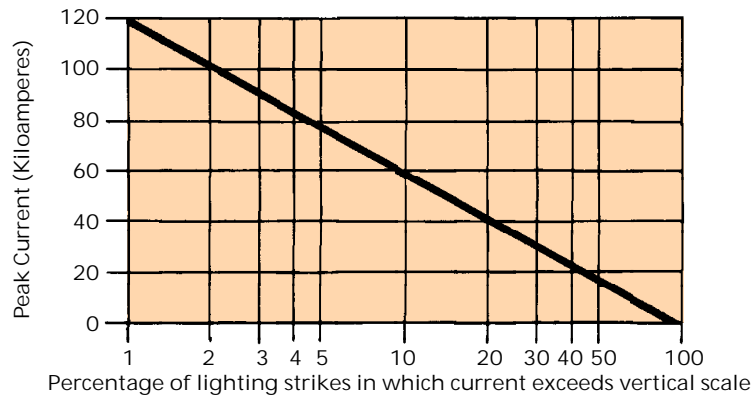

Figure 6-1: Magnitude distribution of currents in lighting strikes to structures

upon meteorological factors. Figure 6-1 shows the magnitude of strike currents to antenna structures.

### Types and Incidence of Thunderstorms

Thunderstorms are generally of two types: convection storms and frontal storms. Convection storms occur in a local area and are of relatively short duration; frontal storms extend over greater areas and may continue for several hours. Convection type storms account for the majority of annual thunderstorms in North America.

The formation of a convection thunderstorm tends to depend upon local conditions on the ground as well as in the air. Convection storms primarily occur during the summer months since they are caused by local heating of the air near the ground. As a result, they typically don't regenerate because the accompanying rain cools the ground and eliminates the storm's source of energy.

Frontal thunderstorms result when a warm, moist front and a cold front meet. These fronts may extend for hundreds of miles and expose large areas to severe and destructive lightning discharges. Such storms are regenerative in nature. As air masses continue to move into the area, the turbulence needed to sustain the thunderstorm is maintained. The magnitude and incidence of lightning strikes to the ground are far greater in frontal storms than in convection storms.

Conditions in the Southeastern United States and in some of the Midwestern states are particularly conducive to frontal

storms in the spring and early summer. Winter storms, which may product large snowfalls, occur occasionally.

Weather observers maintain extensive records regarding the annual incidence of thunderstorm days. This information can be plotted on maps which are often available from governmental weather bureaus for most parts of the world. An example of such a map for the United States is shown in Figure 6-2. By definition, a thunderstorm day is any day during which thunder is heard at a specific observation point. Such observations merely confirm the presence of a thunderstorm and, presumably, some amount of lightning. They do not provide information regarding the type and severity of the storm or the number of lightning strikes that reach the earth.

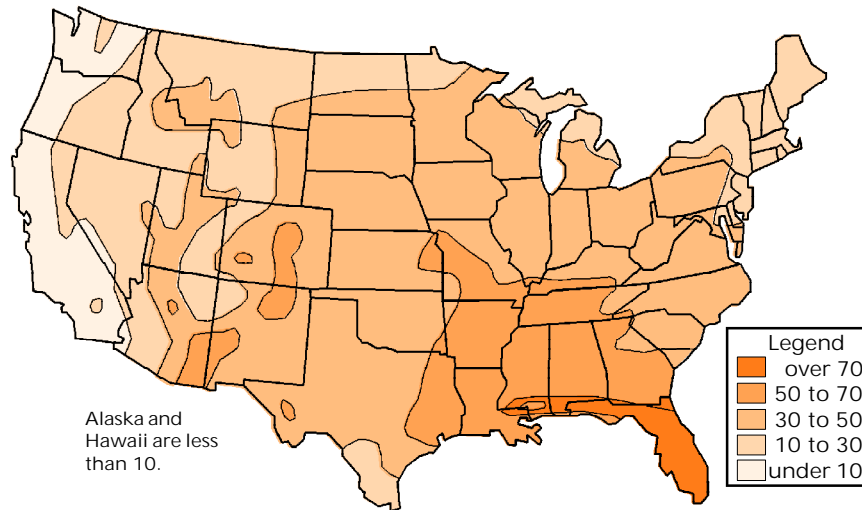

Figure 6-2: Average annual thunderstorm days for the United States

### Cycle of a Lightning Strike

Lightning occurs when the difference between the positive and negative charges — that is, the electrical potential — becomes great enough to overcome the resistance of the insulating air, and to force a conductive path for current to flow between the two charges. Potential in these cases can be as much as 100 million volts. A lightning strike, which in most cases represents a flow of current from negative to positive, may occur from cloud-to-cloud or cloud-to-ground; where high structures are involved, ground-to-cloud strikes may also occur.

The lightning strike that is seen most often is the cloud-to-ground strike. As depicted in Figure 6-3, it begins as a faint, usually invisible, pilot leader. As the pilot leader advances downward, it sets up the initial portion of the strike path. A surge of current called a step leader follows the pilot. The step leader moves toward the ground in increments of 100-feet or more. It repeats the increments until the conductive path of electrified (or ionized) particles is near the ground. There, discharge streamers extending from the ground intercept the leader and complete the conductive channel between the ground and the clouds. When this path is complete, a return strike leaps upward at speeds approaching the speed of light, illuminating the branches of the descending leader track. Because the tracks point downward, the strike appears to come from the cloud. The bright light produced by the strike is the result of glowing molecules of air which are energized by the strike.

Once the channel between the ground and the clouds has been established and the return strike has ended, dart leaders from the cloud initiate secondary returns. Even though the lightning may no longer be visible, current may continue to flow along the ionized channel as the dart leaders continue until the positive and negative charges are dissipated or until the channel is broken up by air movement. Overall, the elapsed time of the strike is roughly one second.

Ground-to-cloud discharges are seen less frequently than the familiar cloud-to-ground strikes. In the ground-to-cloud strikes, step leaders generally advance from a tall conductive or semiconductive structure toward the clouds. Since the charges are less mobile in the clouds than on earth, a return strike from the clouds usually does not occur. However, once the conductive path is established, the current flow may set up cloud-to-ground sequences of dart leaders and returns.

The thunder associated with lightning is caused by the explosive expansion of air as it is heated by the lightning strike. A sharp, explosive sounding thunder is usually heard when the lightning strike is near by while the growling and rumbling sounds of distant thunder are caused as the sound is refracted and modified by the turbulence of the thunderstorm.

Lightning comes in many forms. Streak lightning, which is a single or multiple line running from cloud to ground, is the







Figure 6-3: (1) A cloud-to-ground lightning strike begins as an invisible channel of electrically charged air moving from the cloud toward the ground. As the thunderstorm encounters growing positive charges on earth, the potential between the clouds and the ground increases. (2) A pilot leader starts a conductive channel

form seen most often. Forked lightning shows the conductive channel. Sheet lightning is a shapeless flash covering a broad area, often seen in cloud-to-cloud discharges. Heat lightning is seen along the horizon during warm weather and is believed to be the reflection of lightning occurring beyond the horizon. Ribbon lightning is streak lightning whose conductive channel is moved by high winds, making for successive strikes that seem to parallel one another. Beaded lightning appears as an interrupted strike.

### Introduction to Grounding

Grounding involves more than merely providing a connection between an electrical circuit and the earth. It can be a very effective protection measure, but the design of a practical grounding system is more complex than may be thought.

The reasons for grounding are to:

- Reduce the hazards of electric shock.
- Reduce of noise voltages.
- Protect wiring and circuit components by limiting extraneous overvoltages.

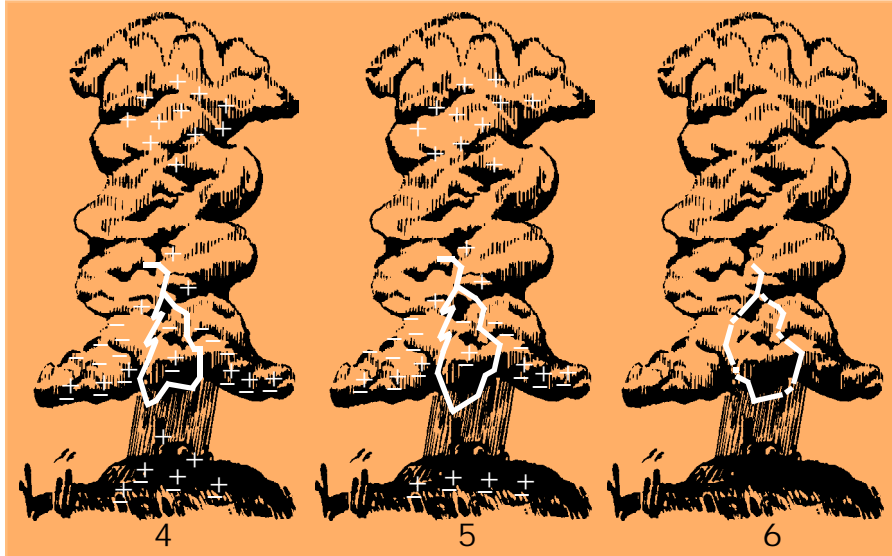

toward the ground, followed by step leaders. (3) The step leaders move downward for short intervals until they are met by upward positive leaders from the ground. (4) The main stroke of lightning is followed by a series of dart leaders and return strokes. (5) The potential is reduced. (6) The ionized path is dispersed. The elapsed time for the entire process is approximately one second!

- Facilitate rapid de-energizing of faulted power circuits.
- Provide a nondestructive path to ground for lightning currents.
- Provide paths to ground for longitudinal (common mode) shielding currents in metallic cable shields, thus reducing induced currents in cable conductors.

### Grounding Philosophy

All electrical facilities are inherently connected to earth either accidentally or intentionally. Since the earth sets a natural common electrical potential, cloud-to-earth lightning seeks the earth as one of its ultimate terminating points. If a conducting path for lightning is provided between the point of contact with a structure and a suitable grounding electrode, physical damage and shock hazards can be substantially reduced.

Electrical systems are designed with sufficient insulation to withstand normal operating voltages and they are usually able to withstand a reasonable value of overvoltage. It's not practical, however, to provide insulation capable of withstanding



exceptionally high voltages, such as lightning. The more practical alternative is to limit excessive voltages by some protective measure such as direct grounding (where possible) or with other protective devices.

### **Equalizing Potentials**

Grounding is an important part of most installations but it is only one of several measures needed to obtain an effective level of protection. Unfortunately, the notion exists that all protection problems can be solved by simply providing a ground; this is not true. All grounding electrodes, including water pipes and ground rods, have a limit to the amount of voltage they can dissipate into the earth. As a result, more must be done than simply running a ground wire to a water pipe. Installations should be equalized by interconnecting all conducting components of the installation. In addition, multiple conductors and grounding electrodes should be provided to increase the amount of voltage that can be dissipated.

### **Antennas and Supporting Structures**

It's fairly safe to say that metal antenna towers mounted into the ground are self-protected. Most two-way radio antennas, antenna horns, dishes, and reflectors are unlikely to be damaged by direct lightning strikes, but they should be adequately grounded to their metal support structures to eliminate arcing. If the ability of an antenna to withstand a direct lightning strike is doubtful, lightning rods should be provided where the transmission pattern permits. The lightning rods may be attached directly to the metallic supporting structure and they should protrude far enough above vulnerable antenna elements to provide adequate protection. Tower-top light fixtures may also be subject to damage if they are not properly protected.

Metal antenna towers — either self-supporting towers or ones using guy wires — provide an excellent conducting path for lightning currents. However, it is vital for the footings, base, and guy wire anchors to be properly grounded.

When wooden poles are used to support antennas, a lightning rod should be provided at the top of the pole. This will give protection against the pole splitting and possible antenna



damage. In a common arrangement, a ground rod is attached to the pole with one end protruding far enough above the top of the pole to provide suitable protection. Typically, a #6 AWG, bare, copper, down-lead is connected to the rod and stapled directly to the pole on the side opposite the antenna feed line. All pole-top hardware, the antenna, and any supporting guy wires should be connected to this grounding conductor. At the base of the pole the shields of lines, equipment cabinets, and any other conducting objects should also be connected to the down-lead. The down-lead should then be connected to the common ground system (see Figure 6-4).

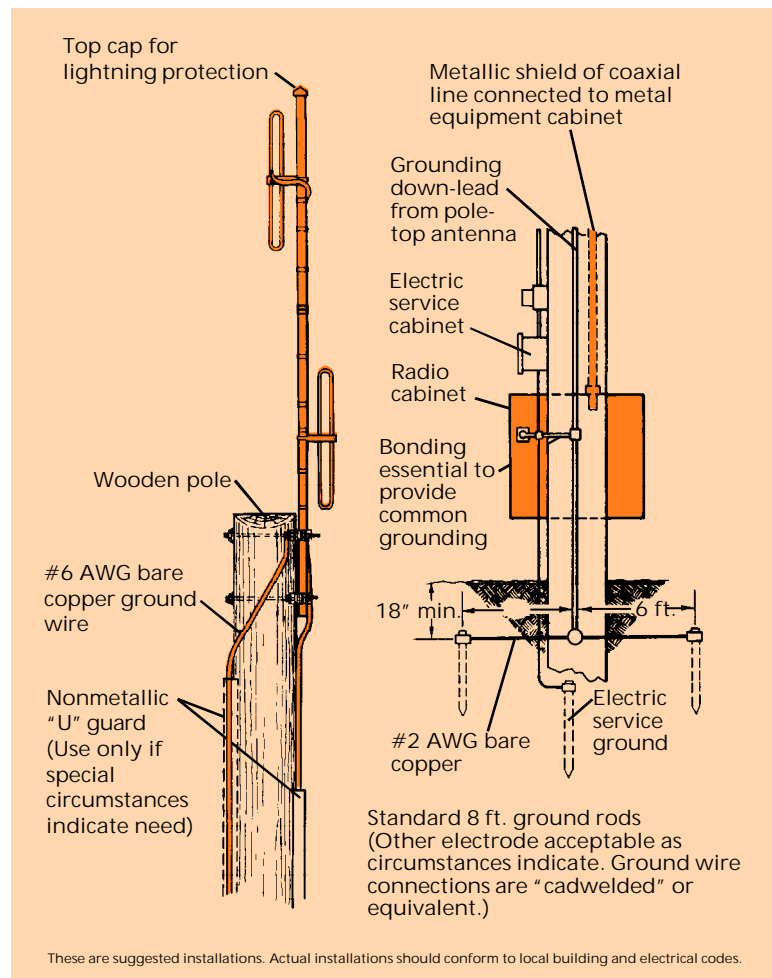

Figure 6-4: Grounding details for a pole-mounted antenna

### **Two-Way Radio Antennas**

Coaxial dipole antennas are frequently protected by a serrated washer that forms a gap between the whip and skirt. This gap should arc over if lightning strikes the whip, essentially providing a short circuit at the antenna. Another means of protecting these antennas is by inserting a quarter-wave shorting stub in the coaxial line at the base of the antenna. When cut to proper lengths according to the antenna's operating frequency, the stub won't degrade normal transmission; instead, it will look like a short circuit to lightning currents. These protection measures will usually prevent dielectric breakdown in the antenna, the line, and connected equipment.

Other types of antennas, such as folded dipole, ground plane, and Yagi antennas, tend to be self-protected. The elements are constructed of metal and are arranged such that a short circuit path is provided for lightning between the elements and the coaxial shield. The metal used is usually large enough to handle high currents.

The trend, however, is away from single dipole devices and toward higher gain arrays such as multiple folded dipoles and collinear multi-element units. The stacked folded dipole array is essentially self-protecting in that the folded dipole elements will short circuit the coaxial feed line at frequencies present in a lightning surge. The metallic tube supporting the elements extends several inches above the top element and consequently shields the array from direct lightning strikes. The collinear dipole antenna usually incorporates resonant line sections housed in a fiberglass tube. Since there is no metal supporting mast for these elements, they must carry all of the lightning current.

### **Microwave Antennas**

Paraboloid (or dish) antennas and horn reflector antennas commonly used for microwave transmission are usually rugged enough to sustain direct lightning strikes without significant damage. Reflectors associated with periscopic arrangements also are not subject to lightning damage. However, lightning rods are frequently used at such installations to protect tower-top warning lights since they are susceptible to damages by a direct lightning strike.



## Two-Way Radio Antenna Support Structures

The grounding arrangement of a typical installation mounted on a wooden pole is shown in Figure 6-4. The antenna shown in this illustration is a top-mounted, stacked, folded dipole. Its support mast is typically a heavy-wall aluminum tube topped by a cap that is located far enough above the top dipole element to intercept lightning strikes. The cap and mast are capable of conducting large lightning currents; therefore, a suitable path to ground is provided by a down-lead from the mast to the base of the wooden pole. At the base, the down-lead is connected to grounding electrodes.

Arrangements other than the ground rods could be equally effective; however, local conditions generally dictate the most practical form to use. For example, long ground rods may be preferable should conditions permit. However, if ground conditions won't permit the driving of ground rods, a radial counterpoise system — which consists of a series of buried conductors that extend outward from the base of the mounting structure and run parallel to the earth — might be considered as an alternative.

If radio antennas are installed on top of buildings, the cable shields, down conductors, and any other conducting objects within 6 feet of the base of the supporting structure should be commonly connected. Then, the entire arrangement should be connected by separate conductors to two grounding systems within the building. Such a system could consist of metallic water pipes, building steel, or other suitable grounds.

Where antennas are supported on metal towers, grounding is simplified. In such cases, antenna masts, cable shields, and all pole-top hardware are connected to the tower. The tower now serves as a grounding path for lightning currents. Suitable connections from the base of the tower to an adequate ground are, of course, required. Details of recommended procedures for grounding metal antenna supporting structures are shown in Figures 6-5, 6-6, 6-7, and 6-8.

## Microwave Antenna Support Structures

Since microwave antennas and their metal supporting structures are essentially self-protected, little in the way of special protection is required at the top of the tower. However,



adequate grounding of metal supporting towers is mandatory. Much of the antenna strike current should be dissipated directly into the earth at the station site. This diverts excessive current away from the connecting land facilities (phone lines,

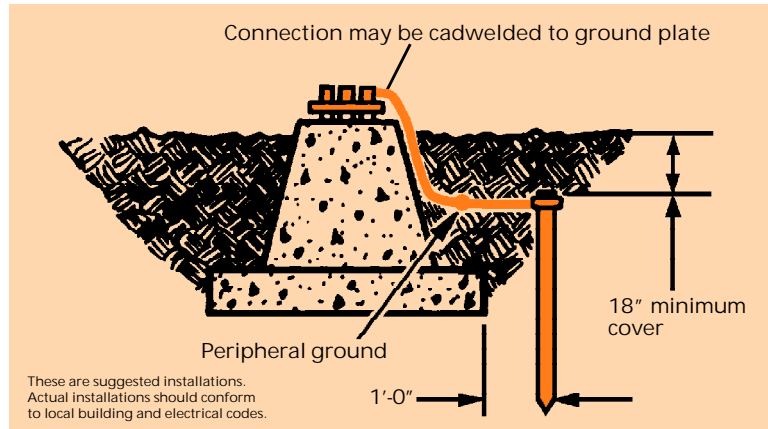

Figure 6-5: Grounding arrangement at tower pier.

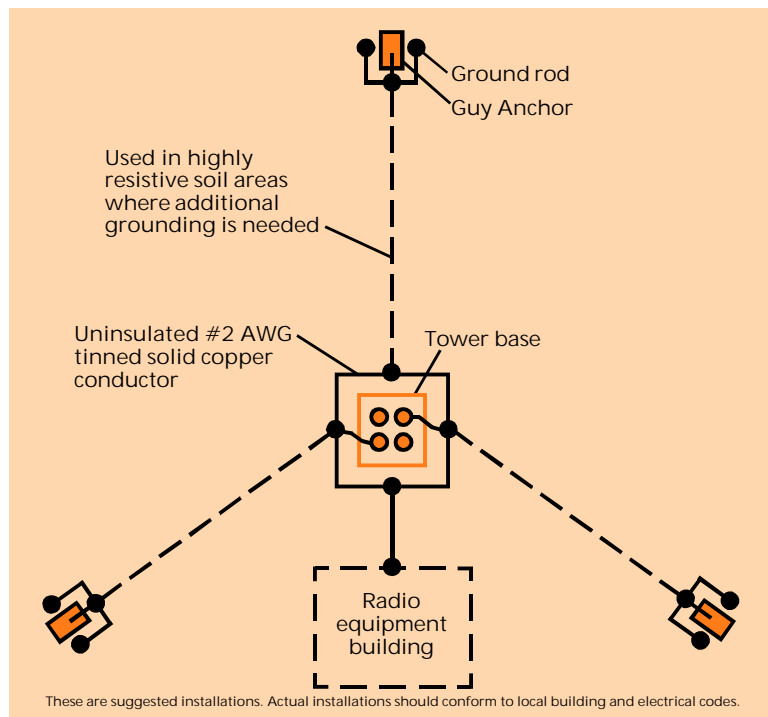

Figure 6-6: Grounding arrangement for a guyed tower.

power lines, Tx/Rx equipment, etc.), thus reducing damage to such facilities.

In recent years, considerable attention has been directed to the effectiveness of concrete-encased grounding electrodes.

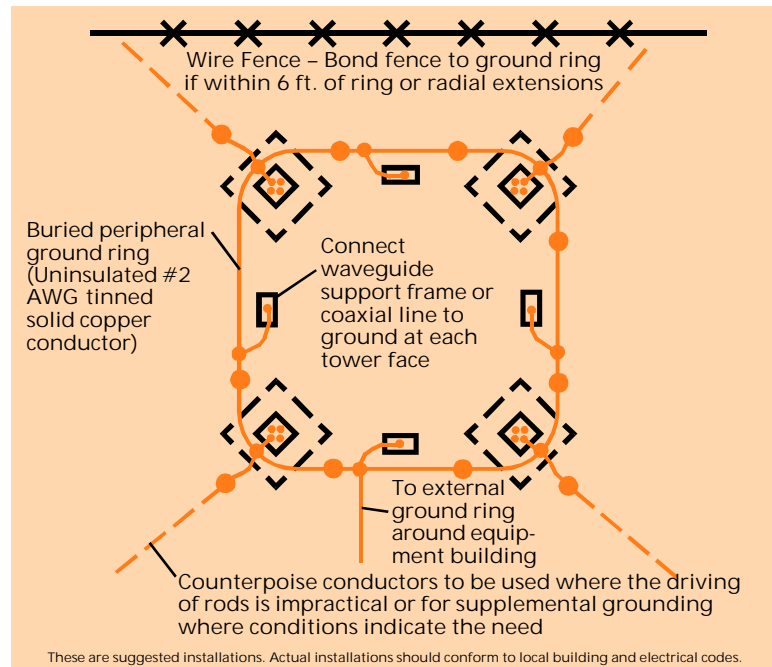

Figure 6-7: Grounding of a freestanding metal tower.

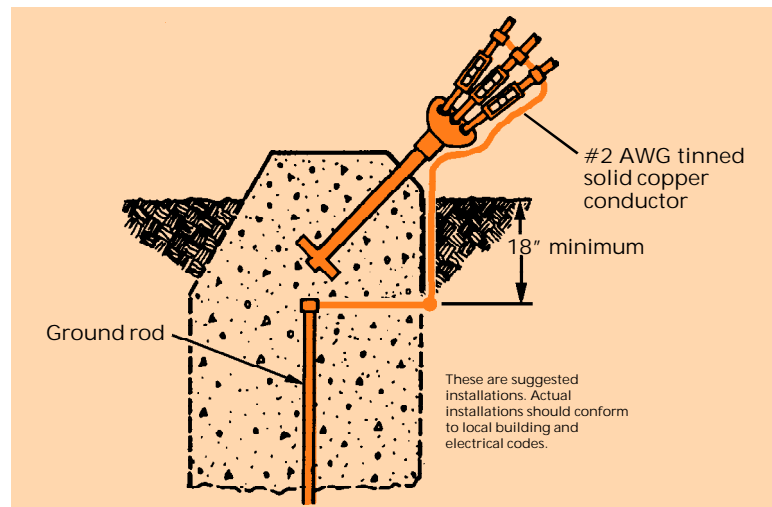

Figure 6-8: Grounding details for tower guy anchor.





Published information indicates that steel reinforced concrete tower footings and guy anchors should be immune from lightning damage, provided that the steel reinforcing bars are welded together to ensure good electrical continuity and then finally welded to the anchor bolts or guy wire eye bolts. This method will reduce the possibility of internal arcing which otherwise might produce explosive damage. In present practice there is generally no guarantee that the hardware and reinforcing in tower footings and guy anchors are electrically continuous. Therefore, supplemental grounding should be used. Also, a perimeter ground ring around tower footings affords local grounding. It also provides a convenient way to connect the tower's grounding system to the buried grounding ring of the equipment building and, finally, to the supplemental radial counterpoise wiring system.

### **Antenna Support Structures on Buildings**

Antenna towers in urban areas are typically mounted on large steel-frame buildings and the radio equipment is usually installed within the building.

When support towers are properly bonded with copper conductors, the steel frames of these buildings offer an excellent ground path through water mains and the building's electrical system. Reinforced concrete structures are not as adequate and proper grounding paths must be provided through down leads that are bonded to metal objects and other suitable ground connections.

Guy wires on a building-mounted tower should be grounded at their base in essentially the same manner used to ground towers. One ground connection per guy wire should be adequate.

Wave guides and the shields of coaxial lines should be bonded to the base of the tower before they enter the radio equipment area. The radio equipment should be well bonded to equalize strike voltages and then grounded as a unit to the same grounding system as the antenna tower.



### **Coaxial Lines and Waveguides**

Coaxial lines are subject to two possible hazards from surge currents flowing in the outer conductors. One hazard is the

induced surge voltages that may damage line dielectrics or associated equipment. The other is mechanical crushing forces which are often caused by surge currents. Small diameter (3/8") air dielectric lines have been crushed by magnetic forces, but solid dielectric lines and the larger diameter air dielectric lines (7/8" and larger) are sufficiently strong to withstand such forces. Providing a shunt path to ground for antenna strike currents will typically solve both problems.

This is easily accomplished in the case of metal poles and towers by bonding the line to the structure at the top and bottom. Where lines are supported at intermediate points, supplemental bonding at each point will eliminate possible arcing. In the case of wooden support structures, a ground wire, as described previously, should be used.

To provide sufficient grounding for flexible sections, waveguides supported on metal structures should be bonded to the structure at the top, bottom, and at intermediate support points. Where the supporting structure cannot be used for this purpose, conducting bonds should be placed across all flexible waveguide sections.

### **Lightning Safety Tips**

Here are a few safety tips that may help save your life when lightning threatens.

If you hear thunder, stay indoors; don't go outside unless it's absolutely necessary. If you can hear thunder, you are close enough to a storm to be struck by lightning. Lightning often strikes outside of heavy rain and may occur as far as 10 miles away from any rainfall.

- During a storm, stay away from open doors and windows, radiators, stoves, metal pipes, sinks, etc. Also, don't use telephones or electrical appliances. Telephone lines, power lines, and metal pipes can conduct electricity. Use the telephone only if it's an emergency.
- Monitor local weather information with a weather radio or AM/FM radio. A battery-powered radio is best since any appliance plugged into an electrical outlet could be a hazard if lightning strikes nearby.



- Don't take a bath or a shower during a storm. Metal pipes (such as water pipes) can conduct electricity.
- Don't do work outside. Don't do yard work and don't take laundry off the clothesline. Don't work on fences, telephone lines, power lines, pipelines, structural steel fabrication, etc.
- Stop tractor work — especially if the tractor is pulling metal equipment — and get off of the tractor. Tractors and other metal implements in contact with the ground are often struck by lightning.
- Don't handle flammable materials stored in open containers.
- Don't use metal objects like fishing rods or golf clubs. (Golfers wearing cleated shoes make particularly good lightning rods.)
- Don't go swimming or boating. Get out of the water and off of small boats.
- Seek shelter in buildings. If no buildings are available, your best protection is in a cave, ditch, canyon, or in a low spot away from trees, fences, and poles. When there is no shelter, stay away from the tallest objects in the area. Also, don't let yourself be the tallest object in the area.
- Avoid hill tops, open spaces, wire fences, metal clothes lines, exposed sheds, and any electrically conductive elevated objects. If you are in the woods, seek shelter under clumps of short trees, away from the taller trees. (If rain accompanies the storm, be aware of the possibility of flash flooding in ditches, streams, low areas, etc.)
- If you are traveling, stay in your vehicle. Vehicles with hard tops offer good lightning protection; avoid vehicles with convertible tops.
- If you are outside and you feel an electrical charge — that is, if your hair begins to stand on end or your skin begins to tingle — lightning may be about to strike you. Squat low to the ground. Place your hands on your knees and tuck your head between your knees. Then, lift your heels off the ground and



rest on the balls of your feet. Make yourself the smallest target possible and minimize your contact with the ground.















**Decibel Products provides  
top-quality products and services  
to meet your RF antenna systems  
and wireless equipment needs.**

**Decibel offers products  
in the 30 to 2000 MHz frequency ranges for:  
PCS, SMR, Paging, Cellular,  
Conventional and Radio Telephone.**

**Featuring:  
Antennas, Cavities, Filters,  
Cable and Connectors,  
Combiners and Multicouplers,  
and Applications Engineering**



**Decibel Products**  
A Division of Allen Telecom Inc.

**8635 Stemmons Freeway • Dallas, Texas 75247-3701  
P. O. Box 569610 • Dallas, Texas 75356-9610  
Phone: 214 / 631-0310 • Fax: 214 / 631-4706**